

# Ultrasonic Diffuse, Analogue Output Types UA18CSD.....TI

CARLO GAVAZZI



- Cylindrical M18 PBT housing
- Sensing distance: 40-800 mm
- Power supply: 10-30 VDC
- Outputs: 0-10 VDC or 4-20 mA
- Linearity error 1%
- Repeatability 1%
- Beam angle.  $\pm 7^\circ$  or  $\pm 8^\circ$
- Protection: short-circuit and overvoltage
- Protection degree IP 67
- 2 m cable or M12 plug

## Product Description

A family of diffuse ultrasonic sensors with a sensing range from 40-300 mm and 80-800 mm with a resolution as low as 3.0 mm. The sensor contains an analogue output that is either 0-10 V or 4-20 mA. This sensor is the ideal choice

for distance measurement, level measurement, diameter measurement or loop control. Due to the use of micro-processor control the digital filtering makes the sensor immune to most electromagnetic interferences.

## Ordering Key

**UA18CSD08AGM1TI**

Ultrasonic sensor	_____
Housing style	_____
Housing size	_____
Housing material	_____
Housing length	_____
Detection principle	_____
Sensing distance	_____
Output type	_____
Output configuration	_____
Connection	_____
Teach-in	_____

## Type Selection

Housing diameter	Connection	Rated operating dist. (S <sub>n</sub> )	Analogue Output	Ordering no.
M18	Plug M12	40-300 mm	4-20 mA	UA 18 CSD 03 AG M1 TI
M18	Cable	40-300 mm	4-20 mA	UA 18 CSD 03 AG TI
M18	Plug M12	40-300 mm	0-10 V	UA 18 CSD 03 AK M1 TI
M18	Cable	40-300 mm	0-10 V	UA 18 CSD 03 AK TI
M18	Plug M12	80-800 mm	4-20 mA	UA 18 CSD 08 AG M1 TI
M18	Cable	80-800 mm	4-20 mA	UA 18 CSD 08 AG TI
M18	Plug M12	80-800 mm	0-10 V	UA 18 CSD 08 AK M1 TI
M18	Cable	80-800 mm	0-10 V	UA 18 CSD 08 AK TI

## Specifications

<b>Rated operating distance (S<sub>n</sub>)</b>	Reference target: 1 mm metal rolled finish 100 x 100 mm 40 - 300 mm 80 - 800 mm	<b>Temperature compensation</b>	Yes
UA18CSD03 UA18CSD08		<b>Hysteresis (H)</b>	Min. 1%
<b>Blind zone</b>	≤ 40 mm ≤ 80 mm	<b>Rated operational voltage (U<sub>B</sub>)</b>	10 to 30 VDC (ripple included)
UA18CSD03... UA18CSD08...		<b>Ripple (U<sub>rip</sub>)</b>	≤ 5%
<b>Repeatability</b>	1%	<b>No-load supply current (I<sub>o</sub>)</b>	35 mA @ U <sub>B</sub> max
<b>Linear Accuracy</b>	1%	<b>Protection analogue output</b>	Short-circuit and overvoltage
<b>Beam angle</b>	7° ± 2° 8° ± 2°	<b>Output analogue output</b>	AG.. types AK.. types
UA18CSD03... UA18CSD08...			4 to 20 mA 0 to 10 VDC
<b>Adjustment</b>	P1 (farthest setpoint) P2 (nearest setpoint)	<b>Load</b>	4 to 20 mA 0 to 10 VDC
Teach by wire			max. 500 Ω min. 3 kΩ
<b>Resolution</b>	3 mm	<b>Carrier frequency</b>	300 kHz
<b>Temperature drift</b>	0.1%/°C @ -20° to +60° C	<b>Response time analogue output</b>	≤ 400 mS

## Specifications (cont.)

<b>Power ON delay</b>	≤ 900 mS	<b>Rated insulation voltage</b>	500 VAC (rms)
<b>Output switching function</b>	Analogue output with positive or negative slope.	<b>Housing</b>	
<b>Indication</b>		Material body	PBT
Output ON	Yellow LED	Material front	Epoxy-glass resin
Echo ON	Green LED	Material back, plug	Grilamid
<b>Environment</b>		Material back, cable	Grilamid
Installation category	III (IEC 60664/60664A; 60947-1)	Material sealing front	TPE
Pollution degree	3 (IEC 60664/60664A; 60947-1)	<b>Connection</b>	
Degree of protection	IP67 (IEC 60529; 60947-1)	Cable	PVC, grey, 2 m, 4 x 0.32 mm <sup>2</sup> , Ø = 4.7 mm M12, 4-pin (CON. 14-series)
<b>Ambient temperature</b>		Plug	
Operating	-20° to +60°C (-4° to +140°F)	<b>Tightening torque</b>	≤ 1 Nm
Storage	-35° to +70°C (-31° to +158°F)	<b>Weight</b>	
<b>Vibration</b>	10 to 55 Hz, 1.0 mm/6g (IEC/EN 60068-2-6)	Cable version	135 g
<b>Shock</b>	30 g / 11 mS, 3 directions (IEC/EN 60068-2-27)	Plug version	65 g
		<b>CE-marking</b>	Yes
		<b>Approvals</b>	cULus (UL508)

## Detection Range

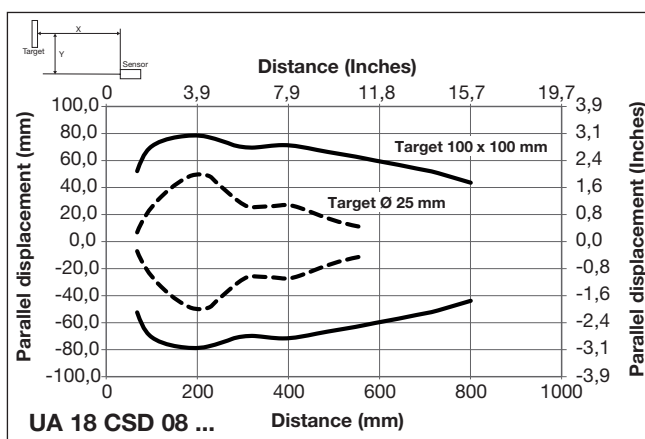
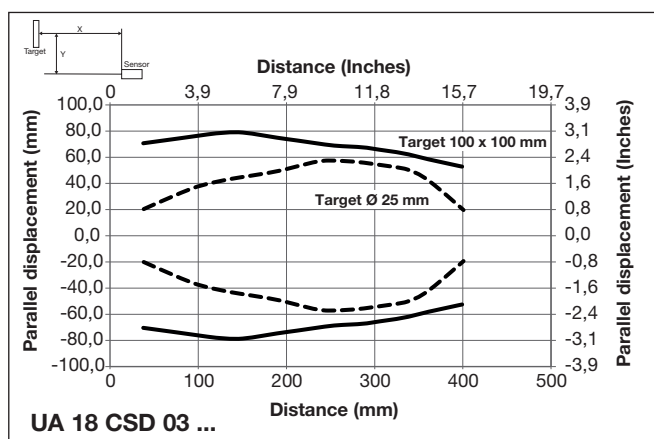

## Wiring Diagram

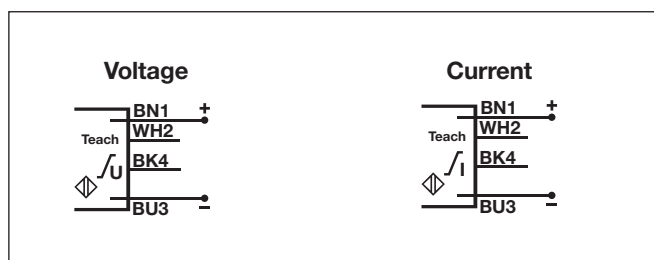

## Dimensions

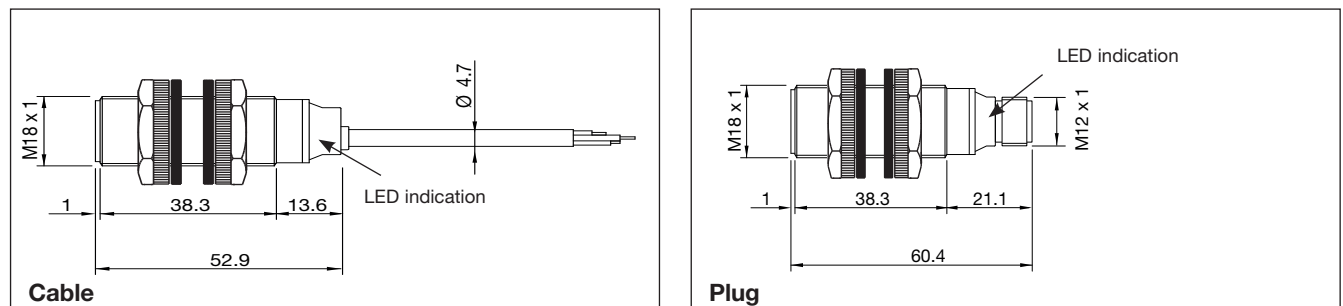

## Programming set-up

### Teach-in by wire adjustment options

Two Teach-in adjustment options are available:

In the following, **“Activate Teach”** means:  
Connect the white wire to GND (Blue wire)

#### 1) Window Teach-in Option (adjustment of two points: P1 and P2)

*Teach-in of set point P1:*

- Place the target at the selected far distance P1 - the green Echo LED is ON
- “Activate Teach” shortly
- Setpoint P1 has been stored and the sensor is still in teach mode
- The orange LED will continue flashing rapidly with a frequency of 2 Hz until the setpoint P2 has been learned

*Teach-in of set point P2:*

- Place the target at the selected close distance P2 - the green Echo LED is still ON
- “Activate Teach” shortly
- The green LED switch OFF and the orange LED will flash 5 times with a frequency of 2,5 Hz
- Setpoint P2 has been stored.
- The sensor is in normal mode and the green and yellow LEDs are steady.

#### 2) Target adjustment on P1 only (Minimum P2 distance)

*Teach-in of set point P1:*

- Place the target at the selected far distance P1 - the green Echo LED is ON
- “Activate Teach” shortly
- Setpoint P1 has been stored and the sensor is still in teach mode
- The orange LED will continue flashing rapidly with a frequency of 2 Hz until setpoint P2 has been learned
- Without moving the target
- “Activate Teach” shortly
- The green LED switches OFF and the orange LED will flash 5 times with a frequency of 2,5 Hz
- Setpoint P2 has been stored at the minimum distance
- The sensor is in normal mode and the green and yellow LEDs are steady

## Programming set-up (cont.)

### Configuration of the slope of the analogue output

The analogue version's default setting is positive slope.

Change configuration from positive to negative slope:

- "Activate Teach" for more than 6 seconds until the orange LED flashes at a high rate/10 times per second.
- Deactivate Teach: The orange LED flashes 5 times, and the output stage is changed.

### Analogue

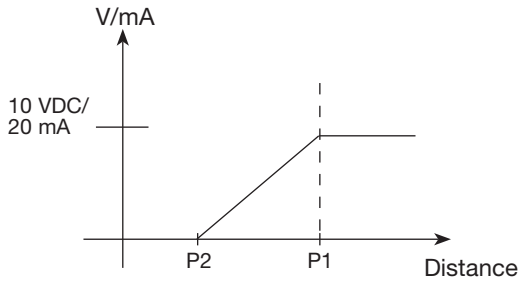

Positive slope

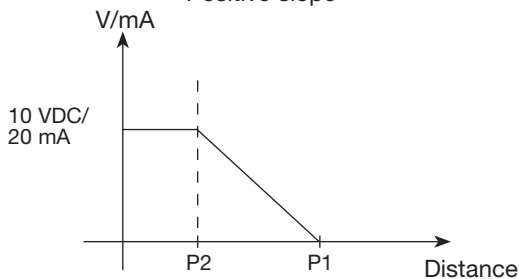

Negative slope

## Installation Hints

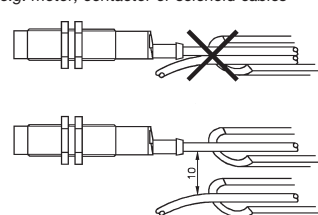
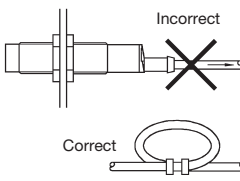
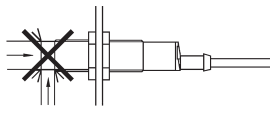
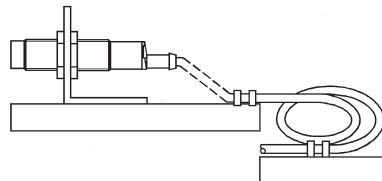
<p>To avoid interference from inductive voltage/current peaks, separate the prox. switch power cables from any other power cables, e.g. motor, contactor or solenoid cables</p> 	<p>Relief of cable strain</p>  <p>Incorrect</p> <p>Correct</p> <p>The cable should not be pulled</p>	<p>Protection of the sensing face</p>  <p>A proximity switch should not serve as mechanical stop</p>	<p>Switch mounted on mobile carrier</p>  <p>Any repetitive flexing of the cable should be avoided</p>
---	---	---	--

## Delivery Contents

- Ultrasonic sensor: UA18CSD....
- Installation instruction
- Mounting:
  - 2 x M18 nuts
  - 2 x rubber washers
- **Packaging:** Carton box 35 x 107 x 173 mm