

Accessories

AC Current Transformer (max 51x15 mm bus-bar)

Type CTD-3X



- Bus-bar type current transformer
- 0.5 class, currents from 50 to 800 A
- Integrated DIN-rail mounting holder
- Removable panel fixing clips
- Up to 6 Bus-bar isolated fixing screws
- Double screw terminals (up to 8-wire connections)
- Sealable terminal block covers

Product Description

Cable/Bus-bar type current transformer with DIN-rail/bus-bar and panel mounting facility. Rated primary currents from 50 A to 800 A.

Ordering Key **CTD-3X 800 5A XXX**



Type Selection

Primary current	Secondary current	Option
From 50 to 800A (Refer to Range Table)	1A 5A	XXX: none XTX: tropicalization

Input Specifications

Operating frequency	45 to 65 Hz
Max. system voltage	0.72 kV
Rated insulation level	3 kV/1 min. @ 50 Hz
Insulation class	E (max 75°C)
Short-time current rating I_{th} I_{dyn}	Typical 100 I_n / 1 s 2.5 I_{th} The short-time thermal current I_{th} is anyway limited by the cable/bus-bar size
Extended current rating	120%
Security factor (FS)	5 (Class: 0.5, 1 and 3)

Special features	Six plastic caps for cable/bus-bar fixing screws. 1 A secondary current, Tropicalization
Working temperature	-25°C to +60°C (-13°F to 140°F) (R.H. < 90% non condensing @ 40°C)
Storage temperature	-30°C to +70°C (-22°F to 158°F) (R.H. < 90% non condensing @ 40°C)
Approvals	CE, cUrus and CSA
Connection Cable cross section area	Screw type From 1.5 to 6 mm ² Min/Max screws tightening torque relevant to terminal block screws: From 1 to 2 Nm Max screws tightening torque relevant to the cable/bus-bar fixing screws: 0,3 Nm
Protection degree	IP00 IP20 (with sealable terminal block covers + wire terminals)
Cable diameter	Max. 41 mm
Bus-bar size Horizontal Vertical	Max. 51x15; 40x20; 32x32 mm Max. 40x20 mm
Weight	From 550 to 700 g

General Specifications

Standards	According to EN60044-1
Housing	ABS, self-extinguishing: UL 94 V-0
Mounting	DIN-rail bus-bar and panel mounting
Standard accessories	Two terminal block screws. Two cable/bus-bar fixing screws. Two plastic caps for cable/bus-bar fixing screws. Two panel mounting fixing clips. Two sealable terminal block covers.
Optional accessories	Extended fixing kit: CTD-kit Two panel mounting fixing clips. Six cable/bus-bar fixing screws.

Output Specifications

Rated secondary current	5 A or 1 A
-------------------------	------------

Range Table

Model CTD-3X from 50A to 200A				
Primary Current	Burden (VA)			
	A	CL 0.5	CL 1	CL 3
50 (@60°C/140°F)				1.75
60 (@60°C/140°F)				2
70 (@60°C/140°F)				2.5
75 (@60°C/140°F)				3
80 (@60°C/140°F)				3
100 (@60°C/140°F)			2	3.5
120 (@60°C/140°F)			2.25	4
125 (@60°C/140°F)			2.5	4.5
150 (@60°C/140°F)	2.25	3		6
160 (@60°C/140°F)	2.5	3.5		6.5
200 (@60°C/140°F)	3	4.5		8.5

Model CTD-3X from 250A to 800A				
Primary Current	Burden (VA)			
	A	CL 0.5	CL 1	CL 3
250 (@60°C/140°F)	3.5	6.5		10.5
300 (@60°C/140°F)	7	10		13
400 (@60°C/140°F)	9	14		17
500 (@50°C/122°F)	14	18		21
600 (@50°C/122°F)	17	21		24
700 (@40°C/104°F)	22	26		29
750 (@40°C/104°F)	24	28		31
800 (@40°C/104°F)	25	29		32

Benefits

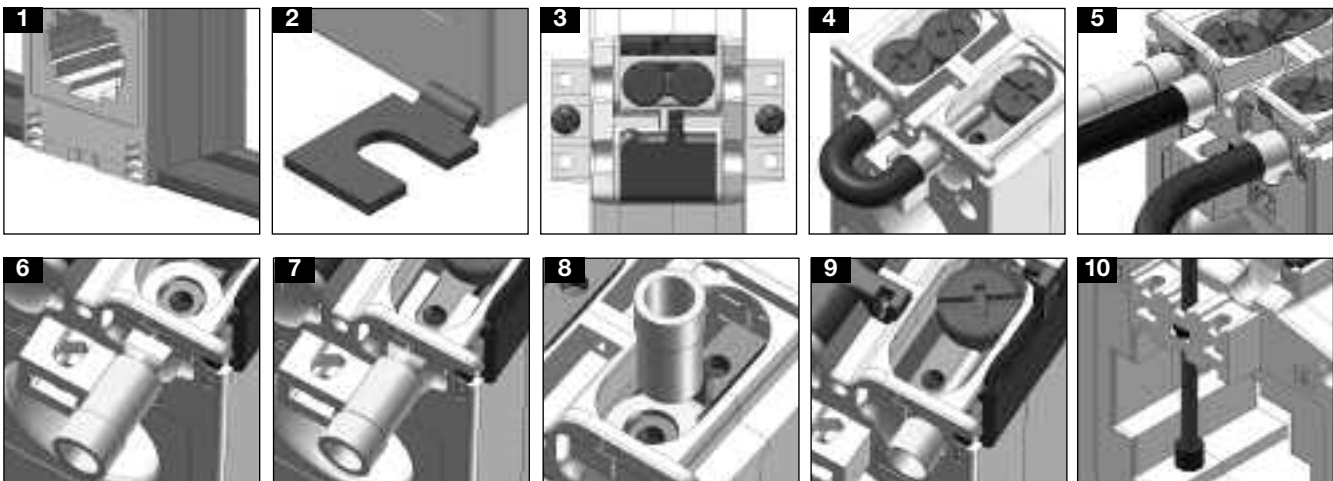

- Easy and quick mounting either on a panel or on a DIN-rail (see figure 1-2).
- Protection of screw terminals using specific sealable covers to assure always the best safety (see figure 3).
- Bridging of current transformer output without changing the connection of the secondary, so to avoid any output overvoltage during either the maintenance or the installation procedure (see figure 4).
- Easy output and earth connection (see fig. 5).
- Screw terminals compatible with any kind of wire terminals (see figure 6-7-8-9).
- Multiple screws provided with isolation cap screws to grant a strong and reliable fixing of the current transformer to the bus-bar (see figure 10).

Dimensions (mm)

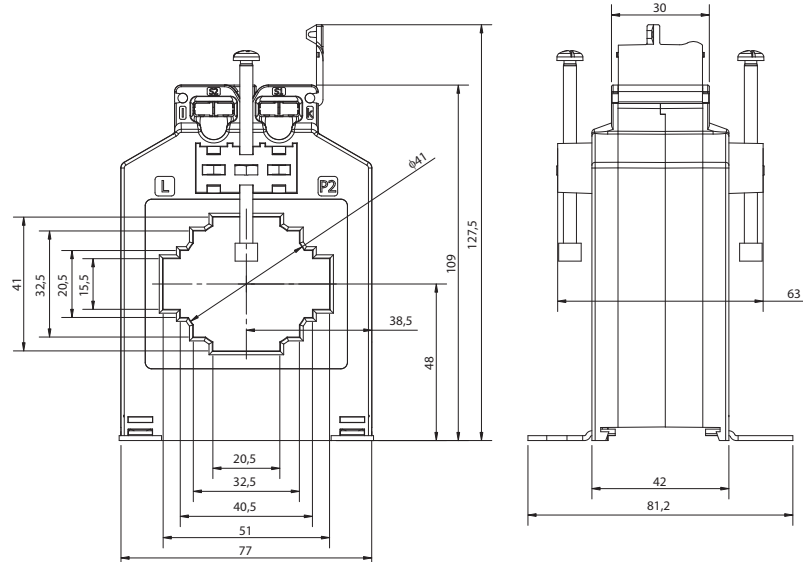

Wiring Diagram

