

Proximity Inductive Sensors Increased Operating Distance, Nickel-Plated Brass Housing - Types ICB, M18

CARLO GAVAZZI



- Sensing distance: 12 to 20 mm
- Quasi-flush or non-flush mountable
- Short or long body versions
- Rated operational voltage (U_b): 10 - 36 VDC
- Output: DC 200 mA, NPN or PNP
- Normally open or Normally closed
- LED indication for output ON, short-circuit and overload
- Protection: reverse polarity, short circuit, transients
- Cable or M12 plug versions
- According to IEC 60947-5-2
- Setup indicator
- Laser engraved on front cap, permanently legible



Product Description

A family of inductive proximity switches in industrial standard nickel-plated brass housings. They are able to handle applications where very long operating distance is requested.

Output is open collector NPN or PNP transistors. Less machine downtime thanks to lower risk of mechanical damage.

Ordering Key **ICB18S30F12NOM1**

Type	_____
Housing style	_____
Housing material	_____
Housing size	_____
Housing length	_____
Thread length	_____
Detection principle	_____
Sensing distance	_____
Output type	_____
Output configuration	_____
Connection	_____

Type Selection

Connec- tion	Body style	Rated operating distance S_n	Ordering no. NPN, Normally open	Ordering no. PNP, Normally open	Ordering no. NPN, Normally closed	Ordering no. PNP, Normally closed
Cable	Short	12 mm ¹⁾	ICB18S30F12NO	ICB18S30F12PO	ICB18S30F12NC	ICB18S30F12PC
Cable	Short	20 mm ²⁾	ICB18S30N20NO	ICB18S30N20PO	ICB18S30N20NC	ICB18S30N20PC
Plug	Short	12 mm ¹⁾	ICB18S30F12NOM1	ICB18S30F12POM1	ICB18S30F12NCM1	ICB18S30F12PCM1
Plug	Short	20 mm ²⁾	ICB18S30N20NOM1	ICB18S30N20POM1	ICB18S30N20NCM1	ICB18S30N20PCM1
Cable	Long	12 mm ¹⁾	ICB18L50F12NO	ICB18L50F12PO	ICB18L50F12NC	ICB18L50F12PC
Cable	Long	20 mm ²⁾	ICB18L50N20NO	ICB18L50N20PO	ICB18L50N20NC	ICB18L50N20PC
Plug	Long	12 mm ¹⁾	ICB18L50F12NOM1	ICB18L50F12POM1	ICB18L50F12NCM1	ICB18L50F12PCM1
Plug	Long	20mm ²⁾	ICB18L50N20NOM1	ICB18L50N20POM1	ICB18L50N20NCM1	ICB18L50N20PCM1

¹⁾ For quasi-flush mounting in metal

²⁾ For non-flush mounting in metal

Specifications

Rated operational voltage (U_b)	10 to 36 VDC (ripple incl.)	Indication for output ON	Activated LED, yellow NO version Target present NC version Target not present
Ripple	≤ 10%	Indication for short circuit/ overload	LED blinking (f = 2 Hz)
Output current (I_a)	≤ 200 mA @ 50°C (≤ 150 mA @ 50-70°C)	Assured operating sensing distance (S_a)	$0 \leq S_a \leq 0.81 \times S_n$
OFF-state current (I_o)	≤ 50 μ A	Effective operating distance (S_r)	$0.9 \times S_n \leq S_r \leq 1.1 \times S_n$
No load supply current (I_o)	≤ 15 mA	Usable operating distance (S_u)	$0.9 \times S_r \leq S_u \leq 1.1 \times S_r$
Voltage drop (U_d)	Max. 2.5 VDC @ 200 mA	Repeat accuracy (R)	≤ 10%
Protection	Reverse polarity, short-circuit, transients	Differential travel (H) (Hysteresis)	1 to 20% of sensing dist.
Voltage transient	1 kV/0.5 J		
Power ON delay (t_o)	≤ 20 ms		
Operating frequency (f)	≤ 1500 Hz		



Specifications (cont.)

Ambient temperature	
Operating	-25° to +70°C (-13° to +158°F)
Storage	-30° to +80°C (-22° to +176°F)
Shock and vibration	IEC 60947-5-2/7.4
Housing material	
Body	Nickel-plated brass
Front	Grey thermoplastic polyester
Connection	
Cable	Ø4.1 x 2 m, 3 x 0.25 mm ² , grey PVC, oil proof
Plug	M12 x 1
Degree of protection	IP 67
Weight (cable/nuts included)	
Cable	Max. 150 g
Plug	Max. 80 g
Dimensions	See diagrams below
Tightening torque	
Distance from sensing face from 0 mm to 9 mm	15 Nm
> 9 mm	25 Nm

Setup function	
NO version	
LED flashing (f=0.67 Hz)	$0.8 S_n < S_r \leq S_n$
LED lights continuously	$0 \leq S_r \leq 0.8 S_n (*)$
NC version	
LED flashing (f=0.67 Hz)	$0.8 S_n < S_r \leq S_n$
LED OFF	$0 \leq S_r \leq 0.8 S_n (*)$
	(*): safer installation
Approvals	cULus (UL508)
	CCC is not required for products with a maximum operating voltage of ≤ 36 V
EMC protection	According to IEC 60947-5-2
IEC 61000-4-2 (ESD)	8 kV air discharge, 4 kV contact discharge
IEC 61000-4-3	3 V/m
IEC 61000-4-4	2 kV
IEC 61000-4-6	3 V
IEC 61000-4-8	30 A/m
MTTF_d	850 years @ 50°C (122°F)

Dimensions (mm)

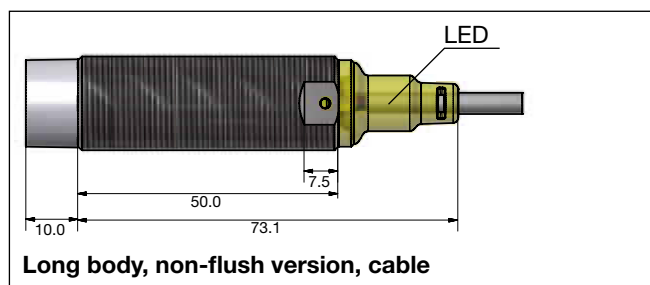
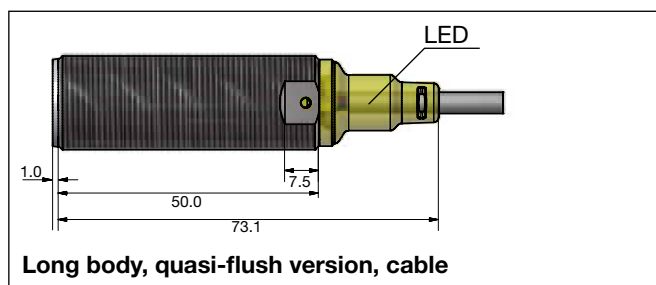
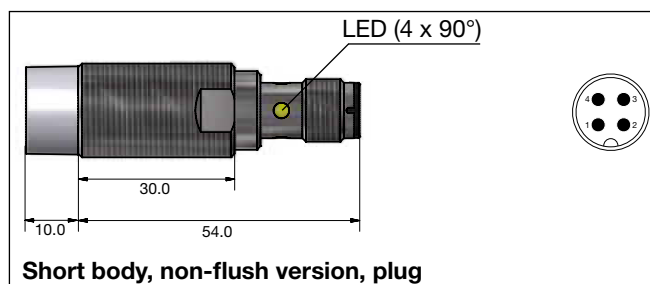
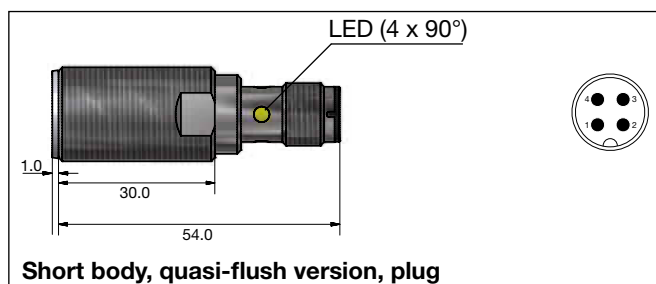
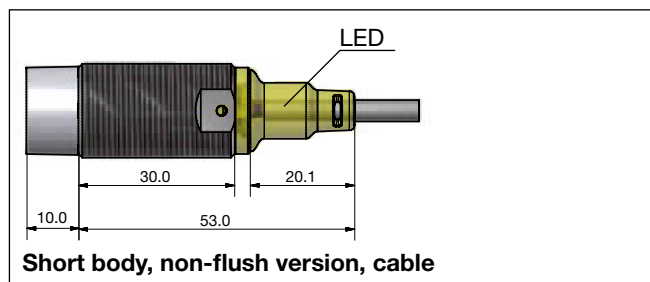
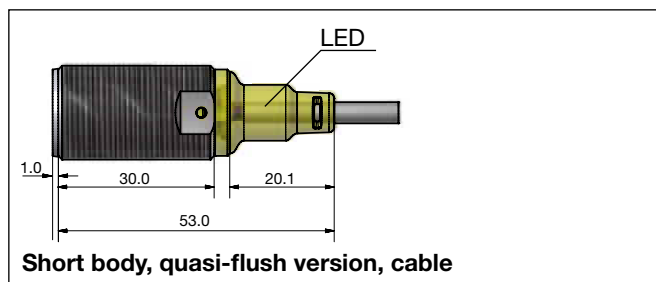

Dimensions (mm) (cont.)

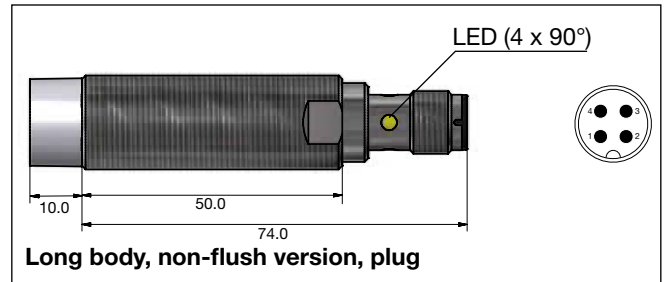
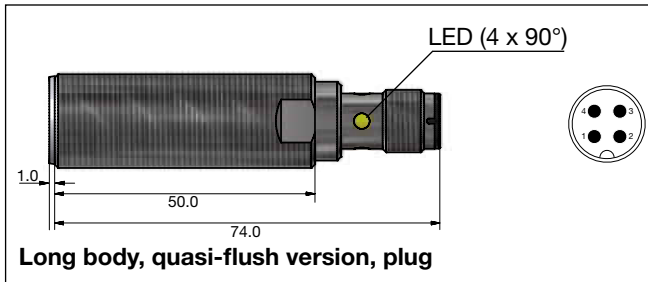

Installation

Quasi-flush mountable proximity switches, when installed in damping material, must be according to Picture 1A.

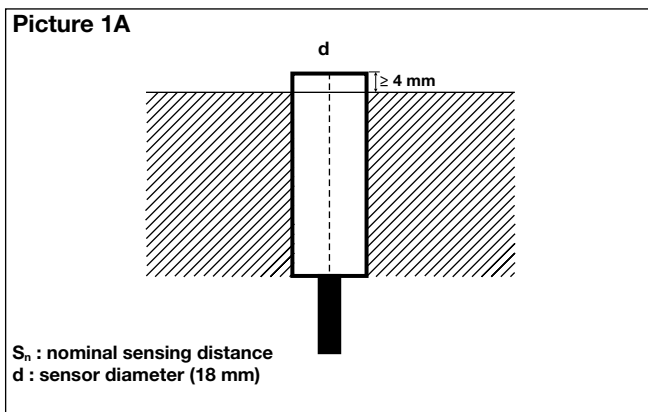

Non-flush mountable proximity switches, when installed in damping material, must be according to Picture 1B.

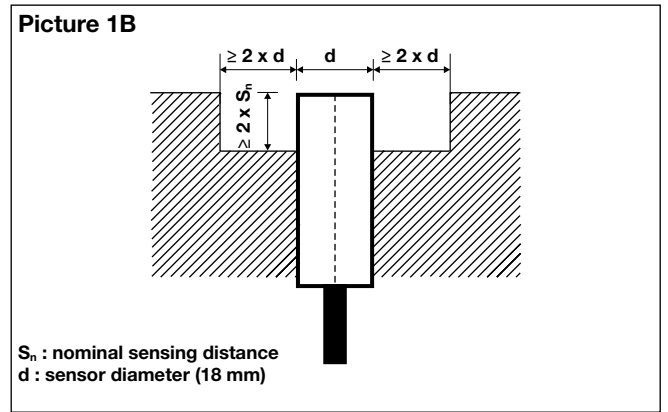

Quasi-flush mountable proximity switches, when installed together in damping material, must be according to Picture 2A.

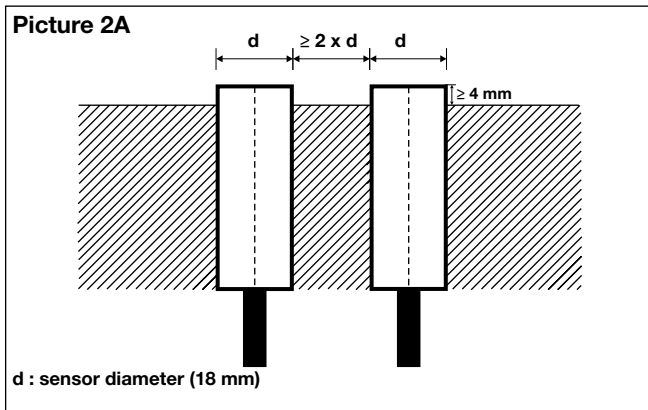

Non-flush mountable proximity switches, when installed together in damping material, must be according to Picture 2B.

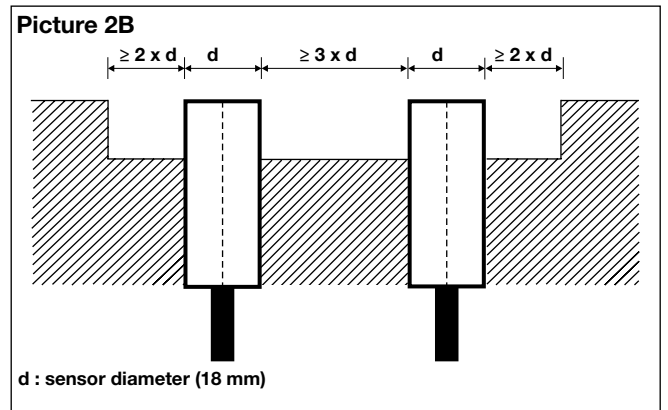

For sensors installed opposite each other, a minimum space of $6 \times S_n$ (the nominal sensing distance) must be observed (See Picture 3).

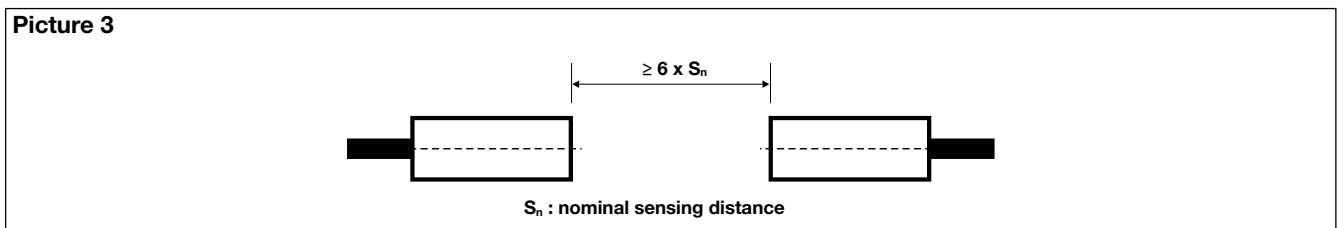



Wiring Diagram

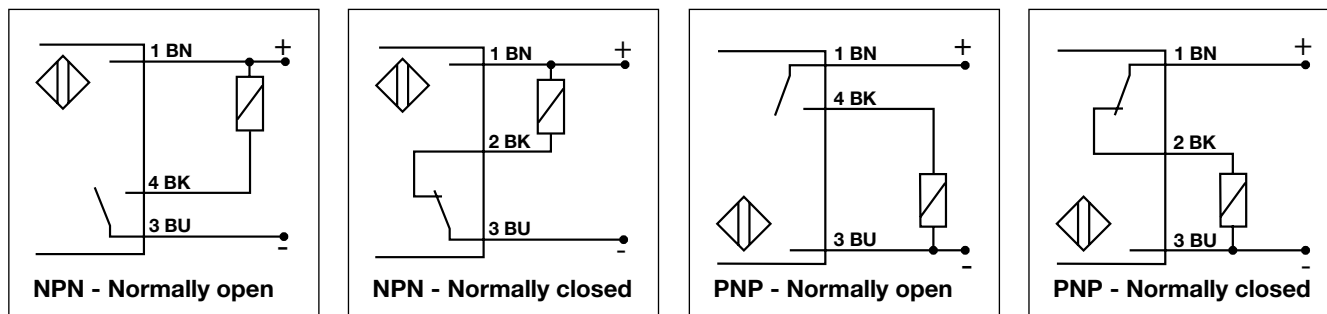

Reduction Factors

The rated operating distance is reduced by the use of metals and alloys other than Fe360.

The most important reduction factors for inductive proximity sensors are shown in Picture 4.

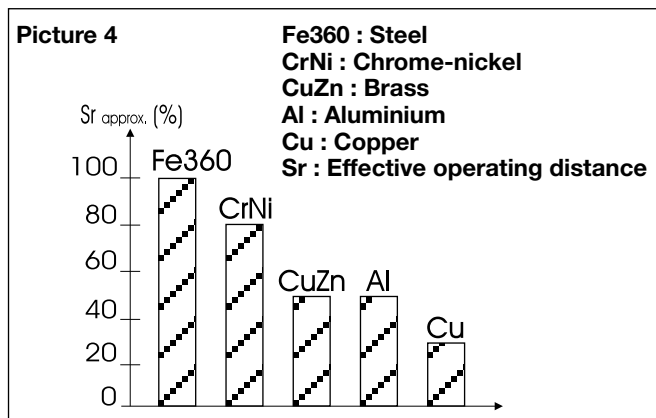

Accessories for Plug Versions

3-wire angled connector, 2 m cable	CONM13NF-A2
3-wire angled connector, 5 m cable	CONM13NF-A5
3-wire angled connector, 10 m cable	CONM13NF-A10
3-wire straight connector, 2 m cable	CONM13NF-S2
3-wire straight connector, 5 m cable	CONM13NF-S5

For any additional information or different options, please refer to the "General Accessories" datasheets.

Delivery Contents

- Inductive proximity switch ICB.
- 2 nuts NPB
- 2 washers
- Packaging: plastic bag