

# SBPBASEx



## Dupline® Carpark base holder for sensor and LED indicator



### Benefits

- Base A and B can be used together with all types of Carpark 3 sensors and LED indicators.
- Plug and play installation.
- Knock-outs for mounting/conduit/ pipe connection.
- On board address chip with SIN code.

### Description

SBPBASEx is part of the Dupline® parking guidance system. It is a base holder for the sensors SBPSUSLx and the indicator SBPILED. The base holder contains the wiring terminals, the chip with the SIN code and a RJ12 connector for the sensor/indicator.

The unit SBPBASEA is designed for cable tray and conduit/pipe mounting where the wires enter the base holder from the top.

The taller SBPBASEB is designed for ceiling mounting, where the cable or conduit/pipe enter the base holder from the side.

### Applications

Parking Guidance Systems

### Main functions

- Base holder for carpark sensors and indicators.

## Features

### Input /Output Specifications

<b>RJ12 connector</b>	Female in sensor Male with cable in base	Internal communication between sensor and base
<b>2 x 3 -pin Connector</b>	Max. 1.5 mm <sup>2</sup>	D+
		D-
		POW

**Note:** The Base 2 x 3 connector are using the “push-wire connection” methode. Use 1.5 mm<sup>2</sup> single core wire or stranded with ferruls for the sensor installation.

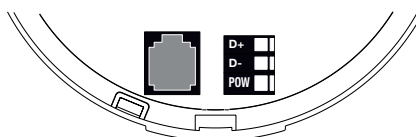

**Fig. 1** Input - Output

### Environmental

<b>Operating temperature</b>	-40 to 70°C
<b>Storage temperature</b>	-40 to 80°C
<b>Humidity</b>	5-90% relative humidity
<b>Pollution degree</b>	3 (IEC60664)

## Mechanics

### Housing

<b>Casing</b>	ABS	
<b>Case Colour</b>	Light grey	
<b>Dimensions</b>	Base A	26 x 116 mm
	Base B	44 x 116 mm
<b>Weight</b>	Base A	25 g
	Base B	40 g

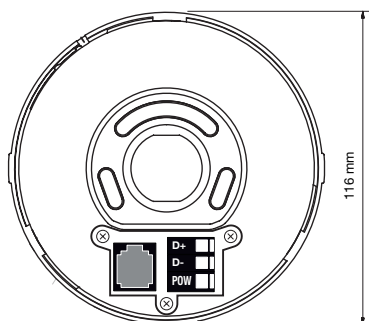

Fig. 2 SBPBASEA

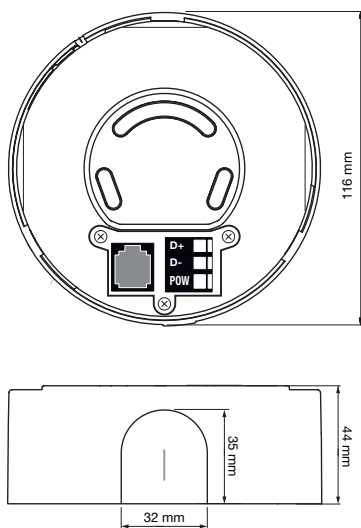
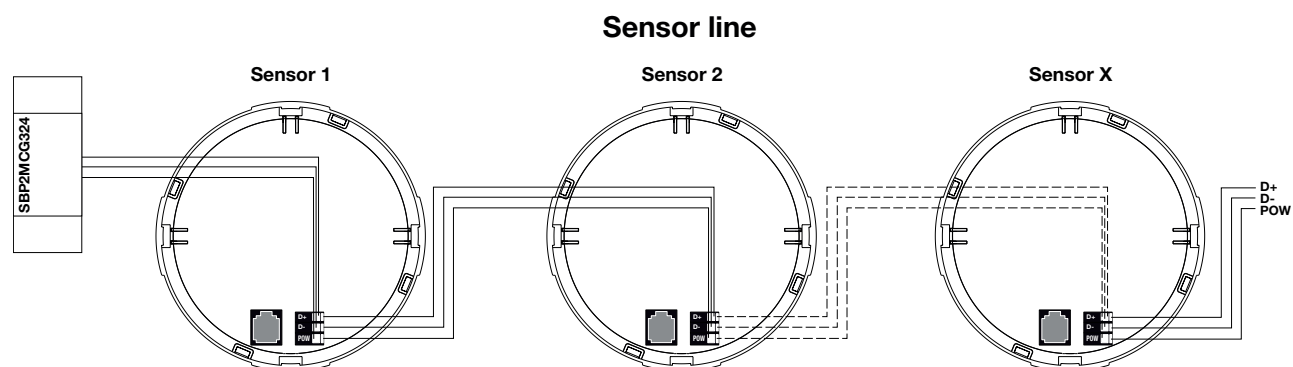

Fig. 3 SBPBASEB

### Wiring



**Note:** The wiring of the sensors must always be made with a 1.5 mm<sup>2</sup> single-core wire, or a stranded wire with ferrules.

## Compatibility and conformity

### Approvals

CE-marking	
Approvals	

#### UL notes

- UL evaluated accessory for Car Park sensor, E345706.
- Max ambient temperature: 50°C (122°F)



## Mode of operation

### Configuration

When base and sensor/led indicator are mounted and powered, they must be programmed by the configuration tool SBP2WEB24.

Entering the configuration tool, the installer can find the SIN number from the connected modules (sensors, LED indicators, Display interfaces etc.) and thereby verify if the module is connected or not.

If connected, the next level is to assign and to program the modules and that is done in the CPY part.

If not connected, the installer must focus on the installation and on the connections of the cables.

Please refer to the SBP2WEB24 software manual for further information.

The software manual can be downloaded from this link; <http://productselection.net/searchproduct.php>

### Mode of operation

SBPBASEx is made in robust ABS material for easy installation in either ceiling or rail.

The unit SBPBASEx is designed for cable tray and conduit/pipe mounting where the wires enter the base holder from the top.

The taller SBPBASExB is designed for ceiling mounting, where the cable or conduit/pipe enter the base holder from the side.

By pressing the knock-outs the installer can in fast way mount cables/pipes/conduit.

SBPBASEx has a RJ12 connector that is used to connect to the sensor or LED indicator. The base holder also has a 2 x 3 pin connector for the Dupline® 3-wire bus with power and communication. The connector is a "push-wire" connector and either single core or stranded wire with ferrules can be used. It is recommended to use unshielded 3x1.5 mm<sup>2</sup> wire for the installation.

Each Base has an Eeprom where the SIN number is stored. When the Base is connected to the sensor/LED indicator and powered, the installer can see the SIN number by using the SBP2WEB24 configuration software.

### Mounting

The sensor/LED indicator must be mounted into either base A or base B.

Place the sensor/LED indicator with the vertical mark so it is at the tip of the triangle on the base.

Turn the sensor/LED indicator clockwise until the vertical mark is positioned at the rear end of the triangle.

The sensor/LED indicator is now fixed to the base.

Release the sensor/LED indicator by pressing in a screwdriver into the vertical slot on the base and turn the sensor/LED indicator anti clockwise.

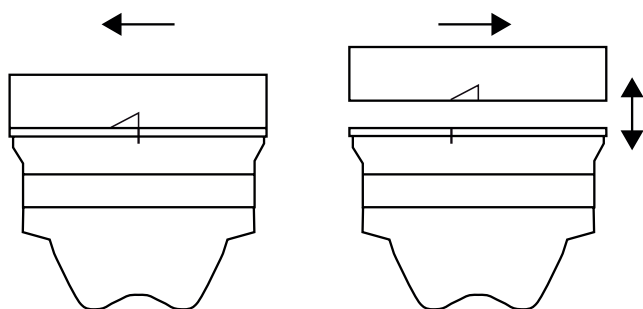

Example on mounting Base A to a Carpark III sensor

Be sure to have enough extra wire for the sensor/LED indicator, so it is possible to make maintenance on the



sensor/LED indicator /base in the future.

Also place the wire correctly to avoid damage on the isolation of the cable. See picture.

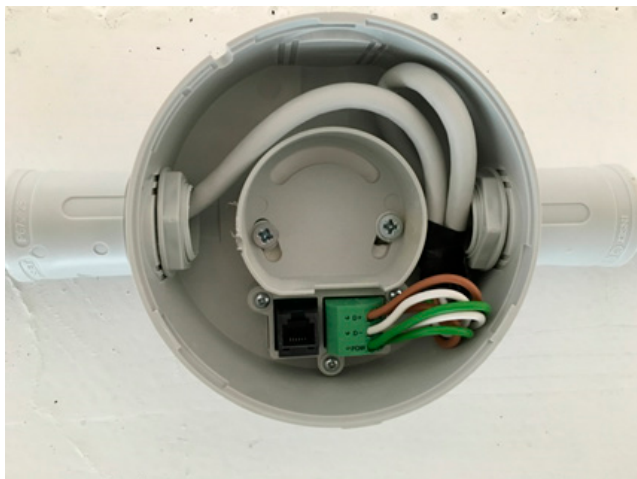

Place the wire around the inner part of the base to avoid damage of the isolation of the cable.

#### Mounting Base in ceiling or rail

When using a sensor with angle such as SBPSUS15, 30 or 45, it is essential to mount the base correctly.

In order to point the ultrasonic beam towards the carpark space, the base must be installed according to the below picture:

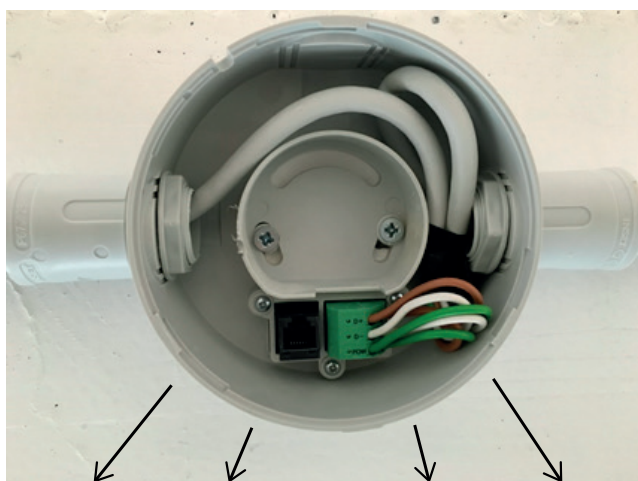

When the sensor is mounted to the base the ultrasonic beams will be send out in this direction.

So in all circumstances must the RJ12 connector and the 2\*3 connector on the base, always be mounted facing towards the carpark space.

If the SBPILED or sensors with vertical angle (0 degree) are used, there are no restrictions according to the ultrasonic beam (sensors).



## References

### Product selection key



SBPBASE

Enter the code entering the corresponding option instead of

Code	Option	Description
SB	-	Smart Building
P	-	Parking
BASE	-	Base
<input type="checkbox"/>	A	Small base for sensor /LED indicator for Carpark
	B	Tall base for sensor /LED indicator for Carpark

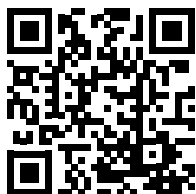

COPYRIGHT ©2016  
Content subject to change. Download the PDF: [www.productselection.net](http://www.productselection.net)