

Smart Building System

Fieldbuses

Smart Building System

Benefit from the Dupline® decentralized solution

Communication networks are used extensively in Building Automation systems at the automation and management levels, but are less used at the device level, especially within HVAC control systems – in most cases, each data point needs its own wire(s) back to the DDC Controller, which complicates the installation in case of widely distributed data points. There can be many good reasons why traditional star wiring is still used, but surely issues with cost and complexity of the available device level fieldbus solutions are important factors. The new Smart Building concept from Carlo Gavazzi is about to change this situation. Because this system significantly simplifies the field level wiring, but without increasing material cost. Furthermore it reduces commissioning time and offers the possibility to integrate HVAC and lighting controls at the field level – one network, two solutions. The system is based on bus-powered sensors and actuators, and small I/O modules. The cost savings of this decentralized I/O solution can be substantial.

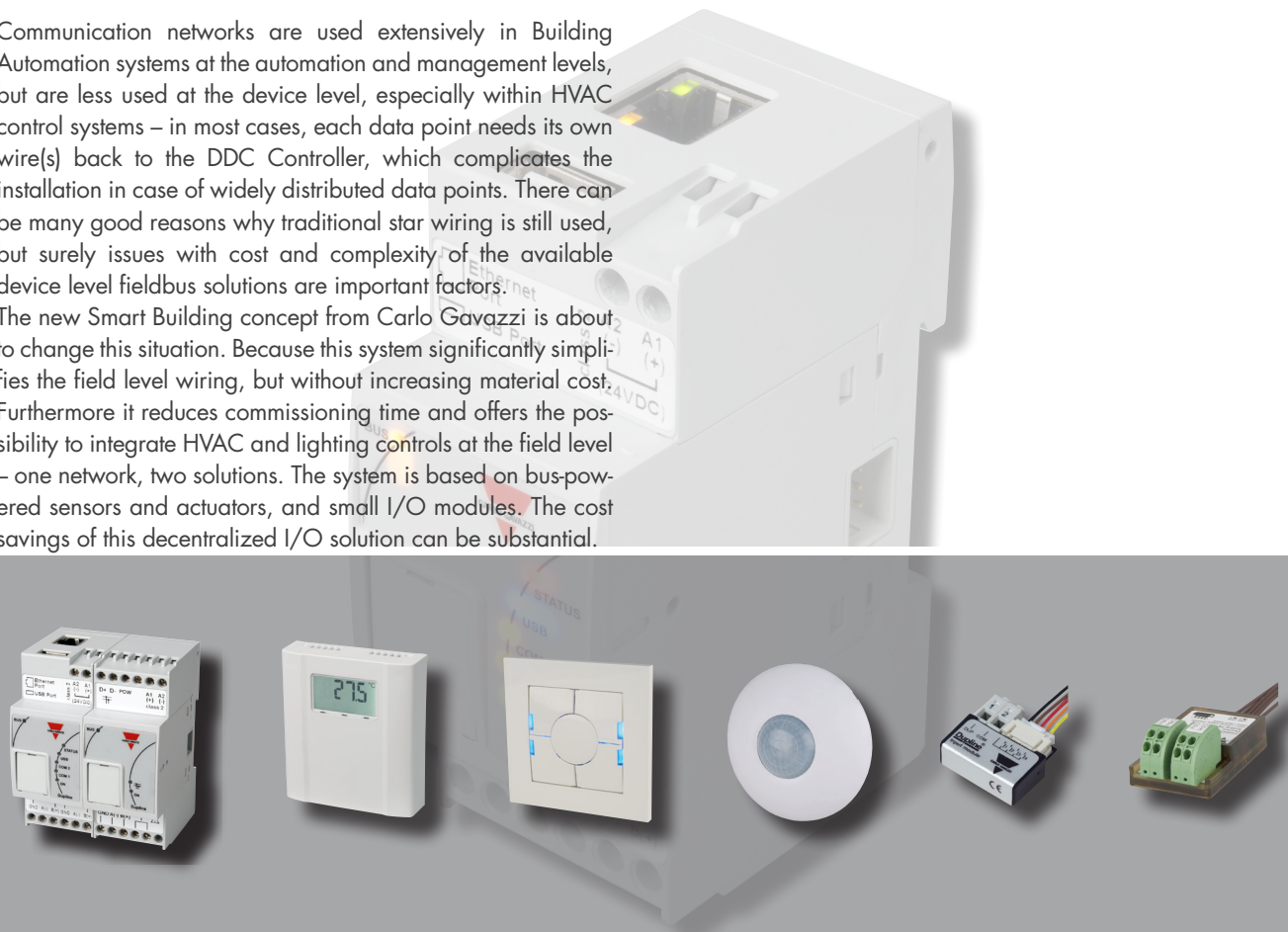

BACnet, DALI and Dupline®

With these 3 fieldbus systems seamless integrated in the SB2WEB controller, any networking requirement within HVAC and lighting control systems can be solved

Integrated HVAC and lighting control

- Bus-powered sensors and actuators for HVAC and lighting are connected to the same Dupline® bus thus eliminating the need for two separate networks and allowing data sharing at the field level
- The SB2WEB is a full featured and fully scalable lighting controller with DALI master capability and can either operate stand-alone or integrated with a DDC control system
- For the HVAC part, the SB2WEB provides a flexible and efficient link to the field I/O via the Dupline® 2-wire bus, while the DDC's run the strategy

Seamless integration with any DDC system

- The BACnet/IP server of the SB2WEB provides a direct seamless interface with industry accepted DDC solutions and building management systems

Simplified wiring at the field level

- The Dupline® 2-wire bus eliminates expensive wiring home runs, saving money on wiring and installation costs versus traditional Device-to-DDC solutions
- The significant installation cost reduction is achieved without increasing material cost due to reduced need for DDC I/O's and standard sensors
- Dupline® is a robust and proven technology with over 150,000 installations worldwide including building automation, mining, oil drilling, railroads, and many, many, more...

Fewer subpanels and DDC controllers

- Distance from subpanel or DDC to field devices is greatly increased using Dupline® 2-wire bus technology
- Number of I/Os of DDC Controller is substantially increased

Flexible, modular and expandable

- System can easily be expanded by simply extending the Dupline® bus cable and adding the desired modules
- System flexibility, backwards compatibility and expandability save costs by minimizing the requirements for the system
- Last minute changes are easily accommodated

Integrated HVAC and lighting control with SB2WEB

The SB2WEB BACnet controller is the brain and central unit of the system. It interfaces to DDC's and the BMS through BACnet/IP, and can manage up to 7 Dupline® bus generators. The Dupline® fieldbus links

together all the sensors, actuators and indicators needed for the HVAC and lighting systems in a free topology network. The robust and noise-immune bus runs on an un-shielded 2-wire cable with no need for end-of-line cable

terminations. Several hundreds of meters cable length can be achieved depending on the load of bus-powered devices and cable dimensions. The DALI master provides the link from Dupline® to the DALI lighting actuators.

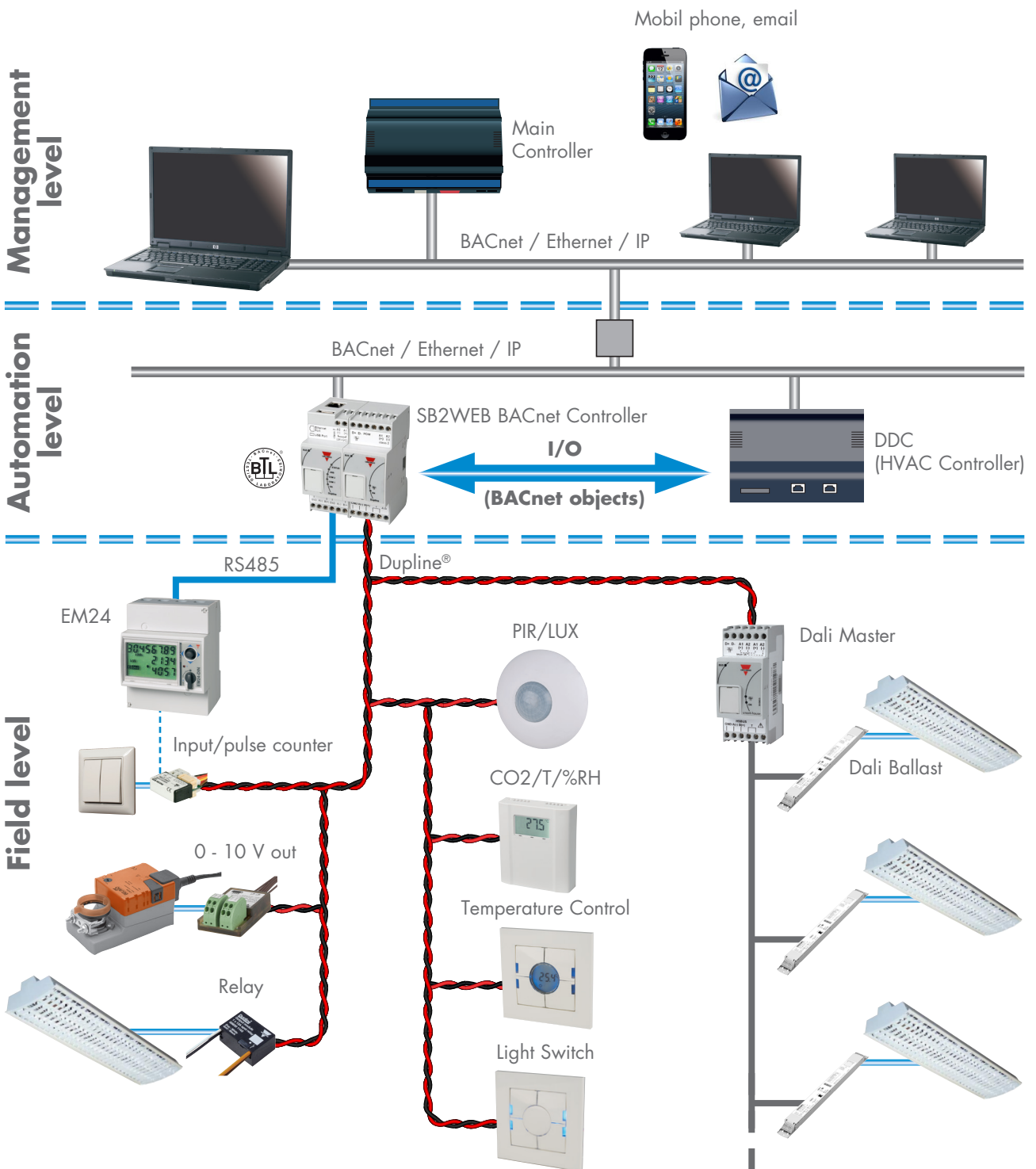

Smart Building System

Benefit from the Dupline® decentralized solution

Completely scalable lighting control

The BTL certified SB2WEB lighting control system is based on a combination of Dupline®, DALI and BACnet/IP. The system has been designed to use these specific bus systems in combination with each other in order to achieve an optimized integrated solution, easy to configure. At the field level, the Dupline® bus is used for the PIR/LUX sensors and light switches typically used in lighting control. The DALI master provides the

link from Dupline® to the DALI lighting actuators, while other lighting loads can be controlled directly by means of Dupline® relays or dimmers. BACnet/IP provides the link to the BMS.

The programming of the entire system with addressing, grouping and functions setup is carried out in a single PC-based configuration tool with seamless integration of data points from Dupline®, DALI and BACnet/IP. This

simplifies commissioning considerably, because there is no need to configure the bridges between the networks, it happens automatically. The system is completely scalable, because each Dupline® network can have up to 7 DALI masters, and each SB2WEB can manage up to 7 Dupline® networks, and multiple SB2WEB's can be linked via BACnet/IP.

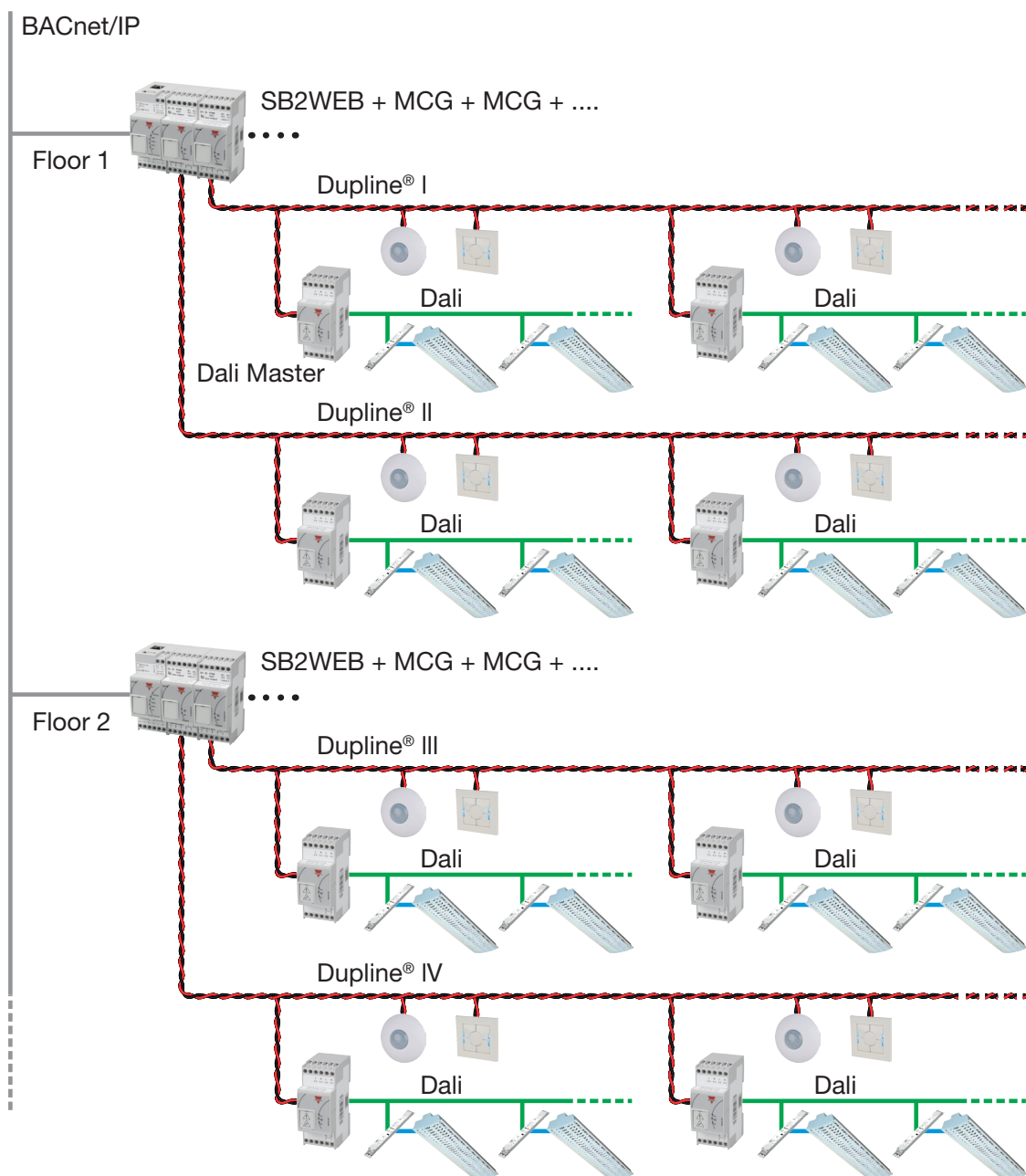

SB2WEB – BACnet controller

The SB2WEB is the controller in Carlo Gavazzi's modular concept for Smart Buildings. The Linux-based controller is equipped with an Ethernet for BACnet/IP and Modbus/TCP communication. Via the two RS485 ports it can collect data from Carlo Gavazzi energy meters and various 3rd party modbus devices,

and subsequently make the all the electrical parameters available as BACnet/IP objects.

Through the local bus connector in the side it connects to up to 7 Dupline[®] driver modules, each able to manage more than 400 data points. Also DIN-rail I/O-modules can be connected this way.

The SB2WEB provides functions for control of lighting, blinds, temperature, logic, scheduling, sequencing, alarms and data logging. The functions can be controlled, monitored and operational parameters changed via BACnet objects, e.g. the lux setpoint for a constant light function.

USB

USB port supports flash for data transfer

Local bus 2

GSM modem

USB, SD

Data transfer using PC or SD card

RS485

Modbus-RTU devices



RJ connection

- BACnet/IP
- Modbus/TCP
- Webserver

Local bus 1

- Communication modules (up to 7)
- Dupline[®]

RS485

Energy meters

Dupline[®] environmental sensors

Carlo Gavazzi's line of bus-powered CO₂, temperature and humidity sensors provides significant wiring advantages in HVAC control systems, especially in those cases where the sensors are widely distributed into several rooms of the building. The Dupline[®] 2-wire

bus cable is simply multi-dropped from sensor to sensor collecting all the measured values – no power supply is required. Furthermore, since the measured values are transferred from the SB2WEB controller to the DDC controller via BACnet/IP, there is no need for expen-

sive analog inputs on the DDC side. If additional sensors are needed later on, it is merely a question of connecting them to the already existing bus cable. The measured values can be shown on the optional backlit LCD display.



Smart Building System

Benefit from the Dupline® decentralized solution

BACnet building controller



SB2WEB24

- BACnet Controller for HVAC and lighting systems
- Functions for control of lighting, blinds, temperature, logic, scheduling, sequencing, alarms and data logging
- Up to 7 Dupline® networks with decentralized I/O can be managed by one SBWEB
- Data Points from Dupline® and Energy
- Meters are automatically converted to BACnet/IP objects
- SBWEB functions and parameters can be monitored and controlled via BACnet/IP objects
- Easy-to-use PC-based configuration tool
- BTL certified
- 2-DIN housing
- DC Power Supply

Bus drivers



SH2MCG24

- Master Channel Generator for one Dupline® bus segment
- Capacity for 120 DigIn, 116 Dig-Out, 256 Analogue I/O
- Provides power and communication for the connected Dupline® modules
- Compact 2-DIN housing
- DC Power Supply

SB2DALI230

- DALI Master
- Connects directly to the Dupline® bus
- Up to 7 DALI masters on one Dupline® bus
- Built-in DALI power supply
- Up to 64 DALI actuators on one SB2DALI230
- Compact 2-DIN housing
- 115-240 VAC power supply

Digital I/O modules - DIN-rail



SH2RE16A2E230

- DC powered module with 2x16A relay outputs and built-in load energy metering (kWh, W, V, A ..)

SH2RE16A4

- Bus-powered module with 4x16A relay outputs

SH2SSTRI424

- DC powered module with 4x10W TRIAC outputs for heating valve control

SH2ROAC224

- DC powered modules with 4x5A interlock relay outputs for control of 2 roller blind motors, AC or D

SH2INDI424

- DC powered module with 4 x NPN, PNP or voltage free inputs. Option to use inputs as pulse counters.

Repeater module



SB2REP230

- Regenerates the Dupline® carrier signal with 300 mA output
- Extends network length
- Isolates the primary and secondary Dupline®
- 230 VAC power supply
- Dimension: 2-DIN housing

Digital input modules - decentralized



BDB-INCON4-U

- Bus-powered small-dimension 4 x contact input module

BDB-INCON8-U

- Bus-powered small-dimension 8 x contact input module

BDB-IOCP8-U

- Bus-powered small-dimension 4 x contact input / 4 x PNP output module

BDA-INVOL-U

- Bus-powered small-dimension 1 x voltage input module

SHPINCNT4 / SHPINCNTS04

- Bus-powered small-dimension 4 x contact / SO input counter module

Digital output modules - decentralized

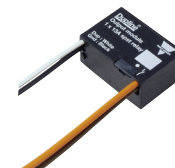

BDA-RE13A-U

- Bus-powered small-dimension 1 x 13A relay output module
- High inrush current capability (130A), thereby suitable for direct lighting loads
- cUL approved

SHDRODC230

- AC-powered small-dimension 2 x 5A relay outputs for control of roller blind motor
- Relay interlock function for roller blind motor protection

NOTE: All modules of the Smart Building system are cUL approved

Analogue I/O modules - decentralized



SHPINNI2

- Bus-powered small-dimension 2 x Pt1000/Ni1000 input module

SHPINT1P1

- Bus-powered small-dimension 1 x 10K3 + 1 x Variable resistor input module

SHPINV324

- DC powered small-dimension 3 x 0-10 V input module

SHPINA224

- DC powered small-dimension 2 x 4-20 mA / 0-20 mA input module

SHPINV2T1P124

- DC powered small-dimension 1 x 10K3 + 1 x Variable resistor + 2 x 0-10 V input module

SHPOUTV224

- DC powered small-dimension 2 x 0-10 V output module

Environmental sensors



- Bus-powered, low current consumption sensors for CO₂, temp. and %RH
- Wall-mounting
- Available in different combinations
- CO₂ measuring range: 0 to 2000 ppm
- CO₂ measurement: Dual source infrared NDIR technology
- Temperature measuring range: -20 to +50°C (-4 to 122°F)
- Humidity measuring range: 0 to 100 %RH

SHSUXXXXD

- Environmental sensor with backlit LCD display

- Touch button in the front to switch on backlighting and select value

SHSUXXXXL

- Environmental sensor with RGB traffic light for CO₂ level indication

SHSUXXXX

- Environmental sensor with blind front plate

PIR/LUX sensors



SHSQP360L

- Bus-powered PIR detector 360° for ceiling mounting

SHXXXP90L & SHSDP90L

- Bus-powered 90° PIR detector with LUX for wall-mounting

SHSPP90L

- Bus-powered 90° PIR detector with LUX for outdoor use

SHSPP90LA

- Bus-powered 90° PIR detector with LUX

NOTE: All modules of the Smart Building system are cUL approved

Light switches



SHE5XLS4TH

- Bus-powered light switch with 4 programmable pushbutton inputs + 4 LED outputs
- Fits into sockets from Gira, Jung and ELKO (55x55 mm)
- Built-in temperature and humidity sensors
- Temperature range: -40 to +60°C (-40 to 140°F)
- Humidity range: 5-95 %RH

SHA4XLS4TH

- Fits into sockets from Schneider (DK), Nico (B) and Legrand
- Other functions and features are identical to SHE5XLS4TH (see above)

Temperature controllers



SHE5XTEMDIS

- Temperature controller with display
- Fits into sockets from Gira, Jung and ELKO (55x55 mm)
- Shows room, floor and outdoor temperatures
- Switch ON/OFF heating / cooling
- Set wanted room/floor temperature
- Energy Save through 3 heating/cooling setpoints

SHA4XTEMDIS

- Fits into sockets from Schneider (DK), Nico (B) and Legrand
- Other functions and features are identical to SHE5XTEMDIS (see above)

Other sensors and detectors



BSN-ANE-U

- Bus-powered wind sensor

BSF-WAT-U

- Bus-powered water leakage detector

BSG-SMOA-U

- Buspowered smoke detector without battery backup

BSG-SMO-U

- Buspowered smoke detector with battery backup

BSH-LUX-U

- Buspowered lux sensor

BSI-TEMANA-U

- Buspowered outdoor temperature sensor

OUR SALES NETWORK IN EUROPE

AUSTRIA

Carlo Gavazzi GmbH
Ketzergrasse 374,
A-1230 Wien
Tel: +43 1 888 4112
Fax: +43 1 889 10 53
office@carlogavazzi.at

FRANCE

Carlo Gavazzi Sarl
Zac de Paris Nord II, 69, rue de la Belle Etoile,
F-95956 Roissy CDG Cedex
Tel: +33 1 49 38 98 60
Fax: +33 1 48 63 27 43
french.team@carlogavazzi.fr

ITALY

Carlo Gavazzi SpA
Via Milano 13,
I-20020 Lainate
Tel: +39 02 931 761
Fax: +39 02 931 763 01
info@gavazziacbu.it

SPAIN

Carlo Gavazzi SA
Avda. Iparraguirre, 80-82,
E-48940 Leioa (Bizkaia)
Tel: +34 94 480 4037
Fax: +34 94 431 6081
gavazzi@gavazzi.es

BELGIUM

Carlo Gavazzi NV/SA
Mechelsesteenweg 311,
B-1800 Vilvoorde
Tel: +32 2 257 4120
Fax: +32 2 257 41 25
sales@carlogavazzi.be

GERMANY

Carlo Gavazzi GmbH
Pfnorstr. 10-14
D-64293 Darmstadt
Tel: +49 6151 81000
Fax: +49 6151 81 00 40
info@gavazzi.de

NETHERLANDS

Carlo Gavazzi BV
Wijkermeerweg 23,
NL-1948 NT Beverwijk
Tel: +31 251 22 9345
Fax: +31 251 22 60 55
info@carlogavazzi.nl

SWEDEN

Carlo Gavazzi AB
V:a Kyrkogatan 1,
S-652 24 Karlstad
Tel: +46 54 85 1125
Fax: +46 54 85 11 77
info@carlogavazzi.se

DENMARK

Carlo Gavazzi Handel A/S
Over Hadstenevej 40,
DK-8370 Hadsten
Tel: +45 89 60 6100
Fax: +45 86 98 15 30
handel@gavazzi.dk

GREAT BRITAIN

Carlo Gavazzi UK Ltd
4.4 Frimley Business Park,
Frimley, Camberley, Surrey GU16 7SG
Tel: +44 1 276 854 110
Fax: +44 1 276 682 140
sales@carlogavazzi.co.uk

NORWAY

Carlo Gavazzi AS
Melkeveien 13,
N-3919 Porsgrunn
Tel: +47 35 93 0800
Fax: +47 35 93 08 01
post@gavazzi.no

SWITZERLAND

Carlo Gavazzi AG
Verkauf Schweiz/Vente Suisse
Sumpfstrasse 3,
CH-6312 Steinhausen
Tel: +41 41 747 4535
Fax: +41 41 740 45 40
info@carlogavazzi.ch

FINLAND

Carlo Gavazzi OY AB
Petaksentie 2-4,
FI-00661 Helsinki
Tel: +358 9 756 2000
Fax: +358 9 756 20010
myynti@gavazzi.fi

PORTUGAL

Carlo Gavazzi Lda
Rua dos Jerónimos 38-B,
P-1400-212 Lisboa
Tel: +351 21 361 7060
Fax: +351 21 362 13 73
carlogavazzi@carlogavazzi.pt

OUR SALES NETWORK IN THE AMERICAS

USA

Carlo Gavazzi Inc.
750 Hastings Lane,
Buffalo Grove, IL 60089, USA
Tel: +1 847 465 6100
Fax: +1 847 465 7373
sales@carlogavazzi.com

CANADA

Carlo Gavazzi Inc.
2660 Meadowvale Boulevard,
Mississauga, ON L5N 6M6, Canada
Tel: +1 905 542 0979
Fax: +1 905 542 22 48
gavazzi@carlogavazzi.com

MEXICO

Carlo Gavazzi Mexico S.A. de C.V.
Calle La Montaña no. 28, Fracc. Los Pastores
Naucalpan de Juárez, EDOMEX CP 53340
Tel & Fax: +52.55.5373.7042
mexicosales@carlogavazzi.com

BRAZIL

Carlo Gavazzi Automação Ltda.Av.
Francisco Matarazzo, 1752
Conj 2108 - Barra Funda - São Paulo/SP
Tel: +55 11 3052 0832
Fax: +55 11 3057 1753
info@carlogavazzi.com.br

OUR SALES NETWORK IN ASIA AND PACIFIC

SINGAPORE

Carlo Gavazzi Automation Singapore Pte. Ltd.
61 Tai Seng Avenue
#05-06 UE Print Media Hub
Singapore 534167
Tel: +65 67 466 990
Fax: +65 67 461 980
info@carlogavazzi.com.sg

MALAYSIA

Carlo Gavazzi Automation (M) SDN. BHD.
D12-06-G, Block D12,
Pusat Perdagangan Dana 1,
Jalan PJU 1A/46, 47301 Petaling Jaya,
Selangor, Malaysia.
Tel: +60 3 7842 7299
Fax: +60 3 7842 7399
sales@gavazzi-asia.com

CHINA

Carlo Gavazzi Automation
(China) Co. Ltd.
Unit 2308, 23/F.,
News Building, Block 1, 1002
Middle Shennan Zhong Road,
Shenzhen, China
Tel: +86 755 83699500
Fax: +86 755 83699300
sales@carlogavazzi.cn

HONG KONG

Carlo Gavazzi Automation
Hong Kong Ltd.
Unit 3 12/F Crown Industrial Bldg.,
106 How Ming St., Kwun Tong,
Kowloon, Hong Kong
Tel: +852 23041228
Fax: +852 23443689

OUR COMPETENCE CENTRES AND PRODUCTION SITES

DENMARK

Carlo Gavazzi Industri A/S
Hadsten

MALTA

Carlo Gavazzi Ltd
Zejtun

ITALY

Carlo Gavazzi Controls SpA
Belluno

LITHUANIA

Uab Carlo Gavazzi Industri Kaunas
Kaunas

CHINA

Carlo Gavazzi Automation (Kunshan) Co., Ltd.
Kunshan

HEADQUARTERS

Carlo Gavazzi Automation SpA
Via Milano, 13
I-20020 - Lainate (MI) - ITALY
Tel: +39 02 931 761
info@gavazziautomation.com



CARLO GAVAZZI
Automation Components

Energy to Components!

www.gavazziautomation.com

