

Langwiesen 7  
A-4209 Engerwitzdorf  
Austria

T: +43-7235-605-0 F: +43-7235-605-8  
E: info@epluse.at I: http://www.epluse.at



## MONTAGE- und BETRIEBSANLEITUNG FEUCHTE / TEMPERATUR MESSUMFORMER Type: SERIE EE06



### ALLGEMEIN:

Messumformer der Serie EE06 sind für die Erfassung von Feuchte und Temperatur bestimmt. Ein kapazitiver Sensor wird als Messelement für die Feuchtemessung verwendet. Anwendung findet die Serie EE06 in Be- und Entfeuchtungsanlagen, bei der Klimatisierung von Museen, bei der Überwachung von Lagerräumen oder feuchteempfindlichen Geräten, wie z.B. Fotokopiermaschinen.

Bei Sonderanwendungen wenden Sie sich bitte an den Hersteller oder an Ihren zuständigen Händler.

### ACHTUNG:

Extreme mechanische und unspezifizierte Beanspruchungen sind unbedingt zu vermeiden. Bei den Typen ohne Gehäuse (EE06-xBx) handelt es sich um ein ESD gefährdetes Teil, d.h. Berührungen während des Betriebes sind zu vermeiden. Bei Wartungsarbeiten sind ESD Schutzmaßnahmen erforderlich.

TECHNISCHE DATEN	
Ausgang entsprechend 0...100%r.F. und -40...60°C	0-1 V
Betriebsspannung SELV	4,5...30 VDC
Stromverbrauch	typ. 1,5 mA (max. 2,5 mA) ohne Ausgangsbelastung
Ausgangsbelastung	max. 0,2 mA
Temperaturbereich Betrieb (Elektronik) Lagerung	-40...60°C -40...65°C
Gehäuse	Polycarbonat / IP65 (Modell A) in senkrechter Montage

### Selbsthilfe bei Fehlern:

Fehler	mögliche Ursache	Maßnahme
unrealistische Werte	nicht optimale Montage	Achten Sie darauf, dass der Fühlerkopf die gleiche Temperatur wie die zu messende Luft besitzt. Bei Freilandanwendung - Strahlungsschutz verwenden! Für die Überprüfung der Ausgangswerte stehen Test Kits zur Verfügung.
zu lange Ansprechzeit	Verschmutzung des Filters Falsche Filtertype	Filtertausch Filtertype ist auf die Anwendung anzupassen
Ausfall des Gerätes	keine Versorgungsspannung	Zuleitung und Versorgungsspannung überprüfen
zu hohe Feuchtwerte	Betauung im Fühlerkopf	Fühlerkopf trocknen; evtl. Filterkappe wechseln.

## INSTRUCTIONS for SETTING UP and OPERATING HUMIDITY / TEMPERATURE TRANSMITTER Type: SERIES EE06



### GENERAL:

The EE06 transmitters are designed to measure humidity and temperature. They use a capacitive sensor element for the humidity measurement. Common applications for the series EE06 are in the field of humidifiers and dehumidifiers, climate controls in museums, monitoring of storage rooms as well as control units such as photostatic machines.

For special applications do not hesitate to contact the manufacturer or the corresponding distributor.

### ATTENTION:

Absolutely avoid extreme mechanical and unspecified strain. Models without housing (EE06-xBx) are ESD sensitive devices. Please avoid touching the device during operation. For maintenance purposes it is recommended, that you observe the valid ESD-safety precautions!

TECHNICAL DATA	
output appropriate 0...100% RH and -40...60°C (-40...140°F)	0-1 V
supply voltage SELV	4.5...30 VDC SELV = Safety Extra Low Voltage
supply current	typ. 1.5 mA (max. 2.5 mA) without output load
output load	max. 0.2 mA
temperature range operating (electronics) storage	-40...60 degC (-40...140°F) -40...65 degC (-40...149°F)
housing	Polycarbonat / IP65 (Model A) in vertical mounting

### Self-help in case of errors:

error	possible cause	remedies
unrealistic values	wrong installation	Please take care that the ambient temperature of the transmitter is the same like the measuring temperature. For outdoor applications use a radiation shield. For rechecking the humidity calibration we suggest to use our Humidity Test-Kits
long response time	pollution of the filter wrong filter type	change filter cap adjust filter type to application
complete failure of the instru-	no supply voltage	check supply cable and supply voltage
humidity values too high	bedewing of the sensor probe	dry the sensor probe and if necessary replace the filter

# Feuchte-/Temperatur Messumformer Serie EE06 Humidity-/Temperature Transmitter Series EE06

## Abmessungen / Dimensions:

1 mm = 0.03937" / 1" = 25.4 mm

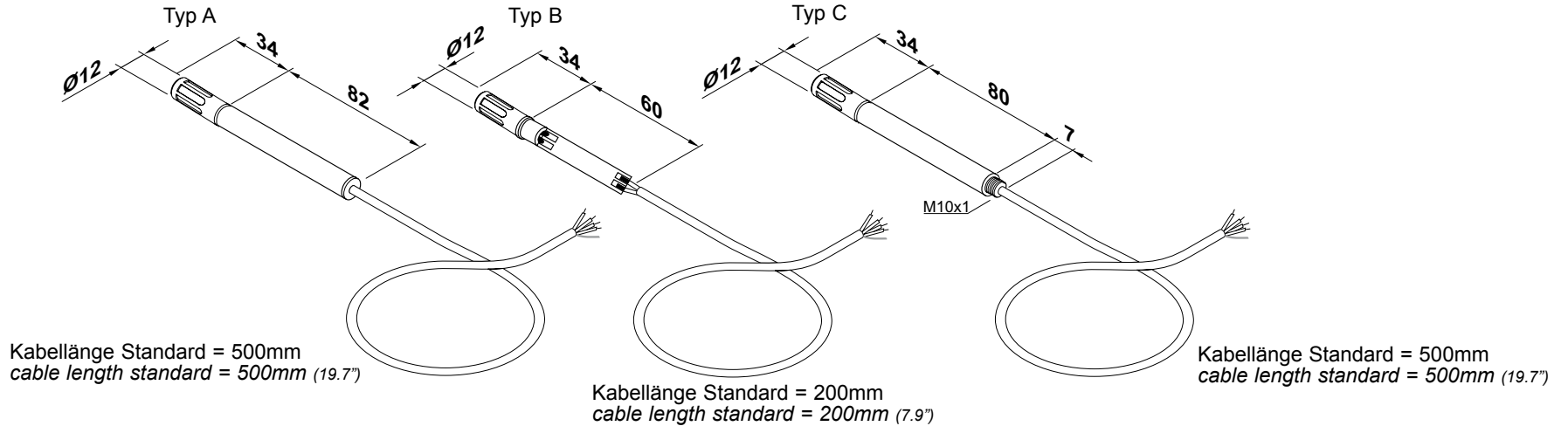

## Anschlussbild / Connection Diagram:

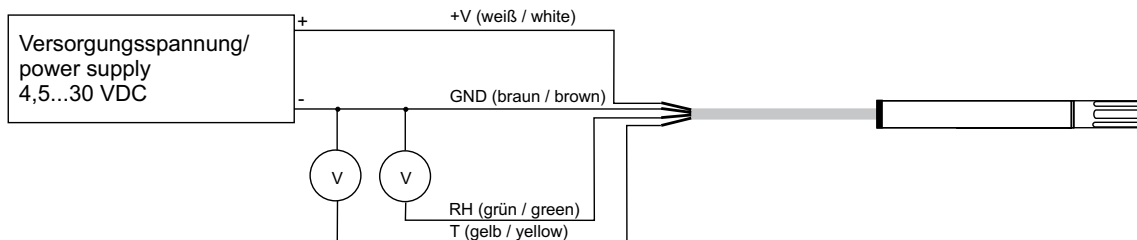

Bei Kabellänge > 500mm ist die Anbindung des Kabelschirms zur Gewährleistung der EMV Kompatibilität zwingend notwendig!

*If the cable length is > 500mm (19.7") connect the cable screening to fulfil the EMC requirements!*

### USA FCC notice:

This equipment has been tested and found to comply with the limits for a Class B digital device, pursuant to part 15 of the FCC Rules. These limits are designed to provide reasonable protection against harmful interference in a residential installation. This equipment generates, uses and can radiate radio frequency energy and, if not installed and used in accordance with the installation manual, may cause harmful interference to radio communications. However, there is no guarantee that interference will not occur in a particular installation. If this equipment does cause harmful interference to radio or television reception, which can be determined by turning the equipment off and on, the user is encouraged to try to correct the interference by one or more of the following measures:

- Reorient or relocate the receiving antenna.
- Increase the separation between the equipment and receiver.
- Connect the equipment into an outlet on a circuit different from that to which the receiver is connected.
- Consult the dealer or an experienced radio/TV technician for help.

### Caution:

Any changes or modifications not expressly approved by the party responsible for compliance could void the user's authority to operate this device.

### CANADIAN

#### ICES-003 notification:

This Device B digital apparatus complies with Canadian ICES-003. / Cet appareil numérique de la classe B est conforme à la norme NMB-003 du Canada.