

SINGLE & DOUBLE ACTING HYDRAULIC PRESSHEAD

RHU1000

CE



ENGLISH

OPERATION AND MAINTENANCE MANUAL

18 M 036 E



WARNING LABELS

TG. 0934

⚠ DANGER	⚠ CAUTION	⚠ WARNING
 <p>ELECTROCUTION HAZARD</p> <p>The user should be properly trained in the correct procedures required for work on or around electrical lines.</p>	<p>Operation and safety methods may vary in accordance with the guidelines of each utility. For your own safety, ensure that you fully comply with all safe operations guidelines required by your respective power utility.</p>	<p>BEFORE USING THIS TOOL READ THE SAFETY WARNINGS and recommended practices described in the manual. Failure by the operator to read and fully understand the warnings will leave this person unqualified to use and operate the tool. Failure to observe all warnings and instructions could result in property damage, severe personal injury or death.</p> <p style="text-align: right;"><small>TG. 0934</small></p>

TG. 0935

⚠ CAUTION TG. 0935

Before operating make sure the latch is secure. Latch improperly secured can cause tool damage and personal injury.

TG. 0947

⚠ WARNING TG. 0947

ONLY OPERATE WITH THE TOP DIE HOLDER IN PLACE

TG. 0356



1 2 3 4

TG. 0356

1	<i>Before using the tool, carefully read the instructions in this manual.</i>
2	<i>When operating the tool, keep hands away from the danger zone.</i>
3 4	<i>Operate only with dies and product inserted.</i>



Keep labels clean and legible, replace if necessary.

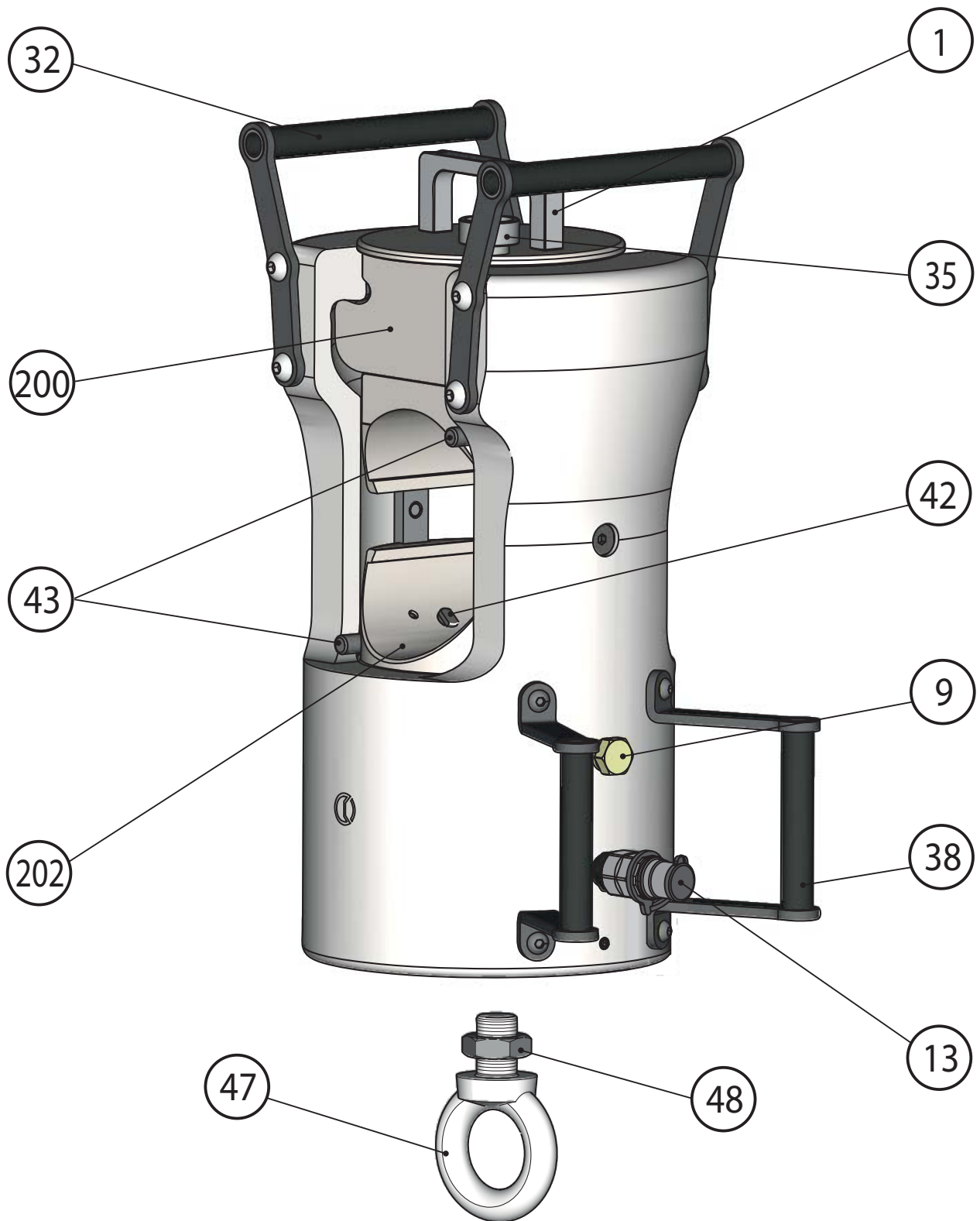

Description:

1	HOLDER HANDLE	42	DIE RETAINING PIN
9	VENT PLUG (for single acting)	43	DIE RELEASE PIN
13	MALE QUICK RELEASE COUPLER	47	LIFTING EYE (for suspended use)
32	LIFTING HANDLE	48	SAFETY NUT
35	DIE HOLDER LATCH	200	TOP DIE HOLDER
38	COUPLER PROTECTION HANDLE	202	RAM



GENERAL SAFETY

- Use this tool for its intended purpose only.
- Inspect tool before use, replace any worn or damaged parts.
- Inspect pump hydraulic hoses and couplings before each use.
- Clear work area.
- Operating & Safety procedures may vary in accordance with the working guide lines established by each utility or contractor.
- For your own safety, ensure that you fully comply with all “safe operation” practices required by your employer.
- To protect from ELECTRICAL SHOCK HAZARD, always wear the necessary clothing & equipment and follow the required safety practices.
Failure to follow these rules may result in serious personal injury or death.
- Before connecting or disconnecting the presshead always disconnect pump / power source and switch to OFF.
- Before connecting the presshead always inspect hoses and couplings.
Always wear eye protection to avoid injury from flying debris or hydraulic oil leaks.
- To avoid tool damage or severe injury, worn or leaking parts must be repaired or replaced, leakage is a sign of deterioration in component parts.

1. GENERAL CHARACTERISTICS

- **Application range:** suitable for installing compression sleeves and lugs on ACSR and ACAR full tension, substation and transmission connections.
- **Supply:** Operable from a single or double acting 10,000 psi hydraulic power source.
- **Crimping force:** 1100 kN (123 sh ton)
- **Max. operating pressure:** 700 bar (10,000 psi)
- **Oil necessary (displacement):**..... 462 cm³ (28.2 cu.in.)
- **Ram stroke:** 30 mm (1.18 in.)
- **Weight:** (without dies)..... 50,7 kg (111.5 lbs)
- **Dimensions:** Ref. to page 15
- **Type of dies:** RHU1000 presshead can accept most 100 ton semi-circular type dies currently used with Alcoa, Burndy, and other 100 ton presses.

2. INSTRUCTIONS FOR USE

2.1) Setting

The head must be transported by two people, always using the handles provided.

Always use RHU1000 on a level and stable surface, e.g the ground. Alternatively, the head may be suspended for use via the lifting eye (47) (refer to § 2.7).

The head is equipped with a "self-lock" quick male coupler and can be connected to **Cembre** single acting hydraulic pumps developing 700 bar (10,000 psi) pressure.

Otherwise it's possible to convert the presshead for use with a double acting pump developing 700 bar (10,000 psi) (refer to § 4).

- SINGLE ACTING COMPRESSION

– Connect the pump hose to the presshead which is equipped with a "self-lock" quick male coupler and can be connected to a Cembre hydraulic pump developing 700 bar (10,000 psi) pressure.

- DOUBLE ACTING COMPRESSION

– Convert the head following instructions as per § 4.

– Check that the power source develops 700 bar (10,000 psi) pressure.

Pay attention to the correct connection of the hoses to the pressure and return ports.

– Connect the return hose to the return port on the power source, then to the female upper coupler on the head. Connect the pressure hose to the lower male coupler on the head, then to the pressure port on the power source.



Hydraulic flow reversal causes malfunction in operation and may result in severe injury or death.

2.2) Die insertion/extraction

– Select the appropriate die set as recommended by the lug or sleeve manufacturer.

– Insert one die in the upper seat of the top die holder (200) until it is locked; to ease the die insertion, keep the pin (43a) depressed.

– Likewise, insert the other die into the seat on the ram (202) by pressing the pin (43b).



Never pressurise the head without top die holder and dies in place as serious damage and /or personal injury may result.

To remove dies, take them off their guides by pushing relevant pins (43a and 43b).

crimping die

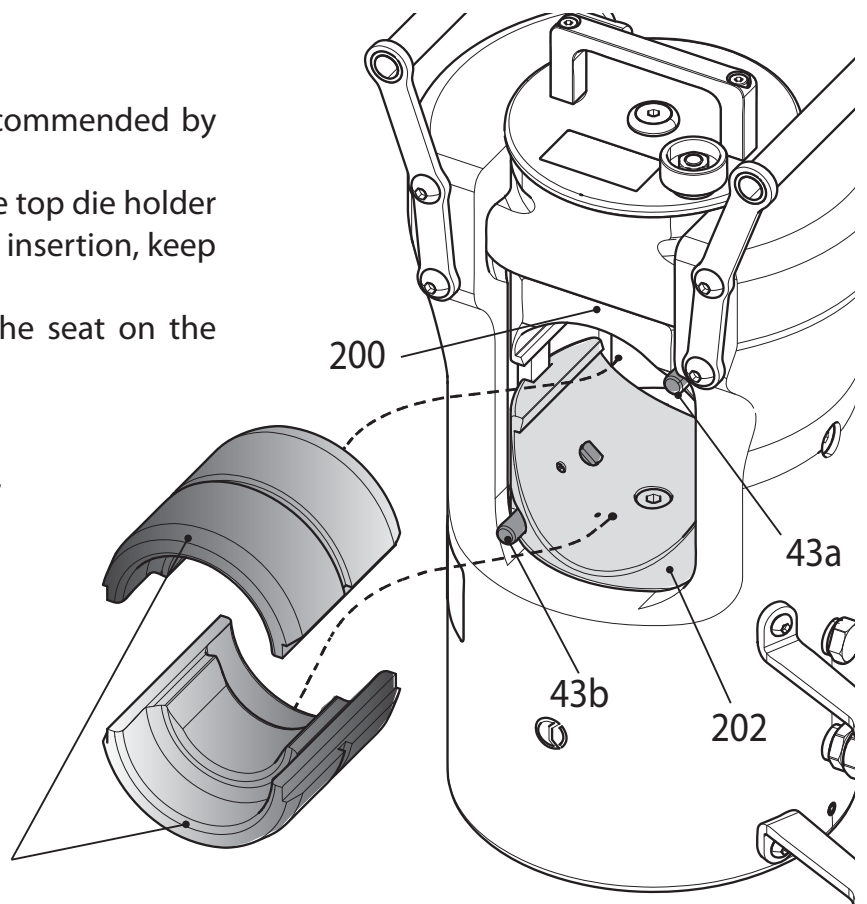

2.3) Ram advancing and die positioning

- Locate the connector between the dies at the crimp position, if necessary open the head following instructions as per § 2.6.
- Operate the pump until the dies touch the connector.

Make sure that dies are exactly positioned on desired crimp point, otherwise re-open dies following instructions as per § 2.5 and reposition the connector.

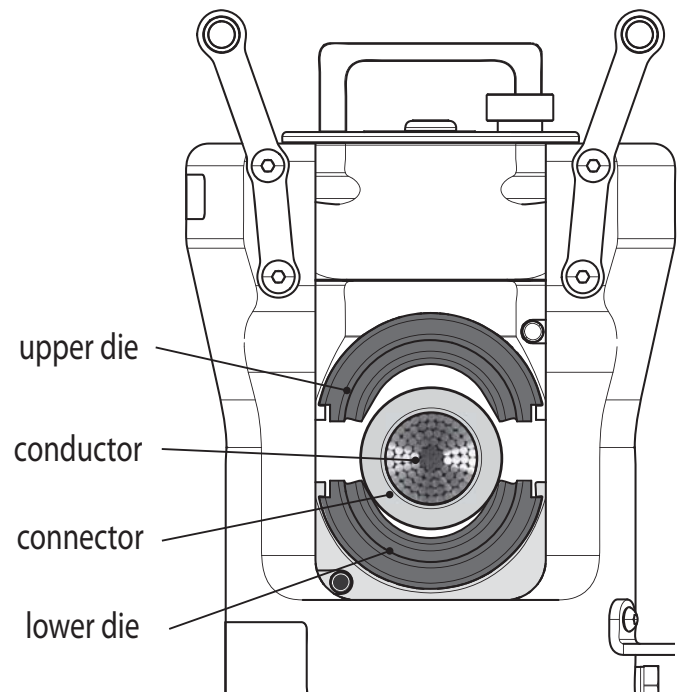

i *Before starting the crimping operation make sure the top die holder is in place and latch is secure. Operating without top die holder or latch improperly secured can cause tool damage and personal injury.*

2.4) Crimping

- Operate the pump to advance the ram (202) until the die faces touch. It is recommended to continue pumping until the maximum pressure valve of the pump is activated and a “click” is heard.
- Re-open the dies (see § 2.5) and repeat steps above as necessary following crimping sequence recommended in the installation instructions of the connector manufacturer.

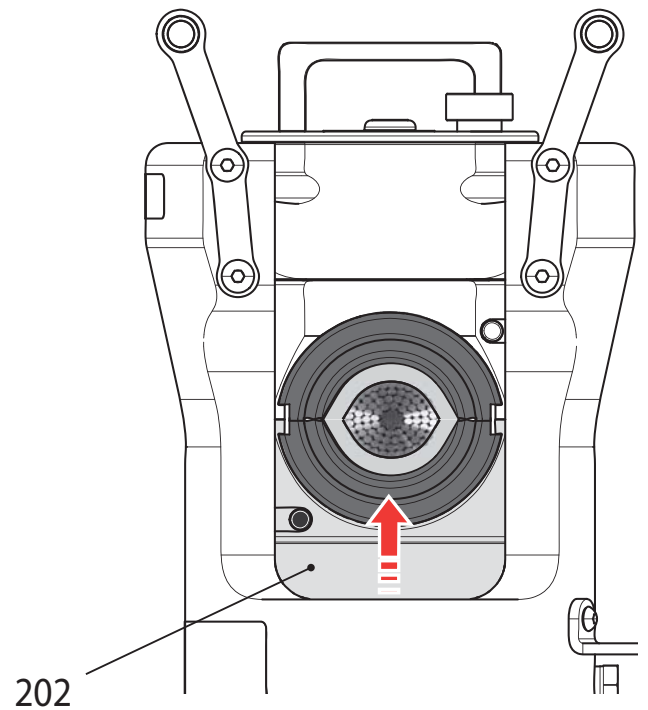

i *Lower pressure may reduce tonnage achieved and reduce crimp integrity. Higher operating pressure may cause structural failure and / or personal injury.*

2.5) Die opening

- Fully discharge the oil pressure from the release device of the pump to retract the ram and release the crimped connector; if necessary open the top die holder to remove the connector (see § 2.6).

2.6) Head opening

When required, the upper part of the head can be removed to permit an easy introduction of the connector or removal of it after crimping.

Proceed as follows (with reference to **Fig. a**):

- 1 Hold the handle (1) and pull the latch (9).
 - 2 Turn the top die holder (200) through 90 degrees.
 - 3 Remove the top die holder (200).
- Insert the conductor into the connector and introduce the connector into the head.
- 1 Relocate the top die holder (200) (Refer to **Fig. b**).
 - 2 Pull the latch (9).
 - 3 The holder automatically turns into the locking position (Refer to **Fig. c**).

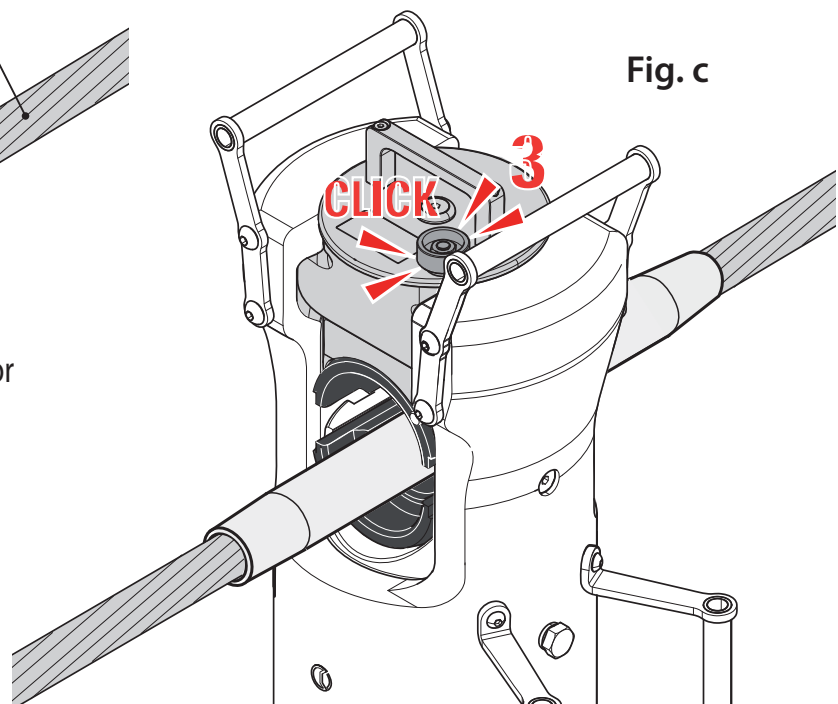
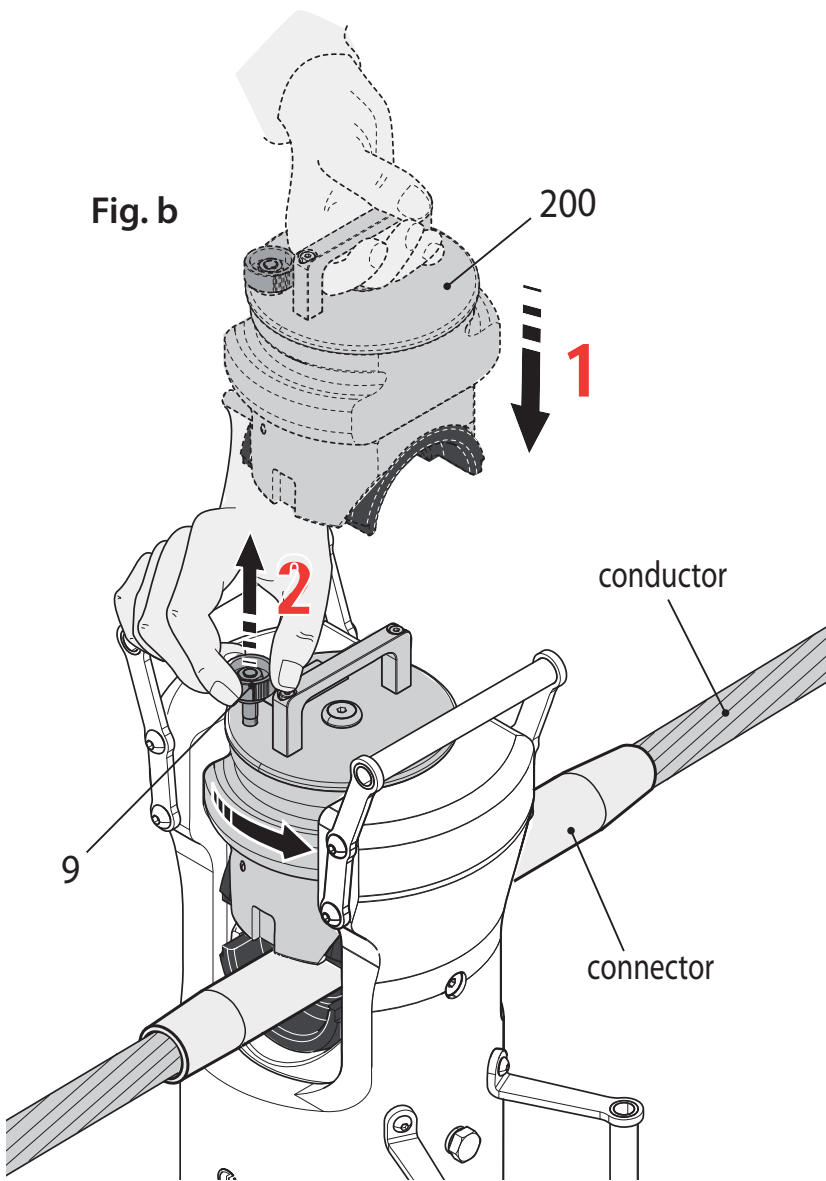
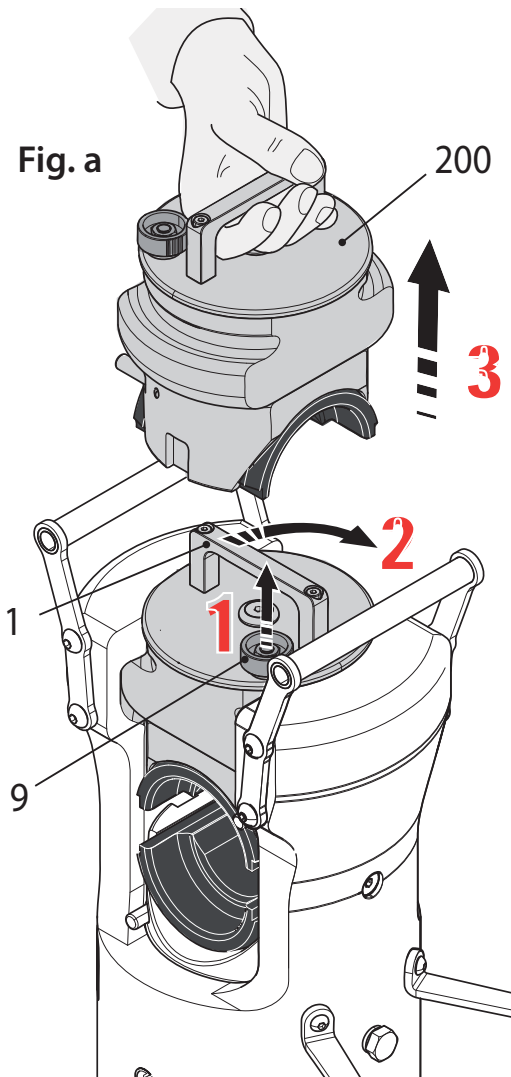

i Before crimping operations, check that the head is correctly reassembled and latch (9) is correctly located.

2.7) Lifting eye installation

To use the head in suspension mode for aerial operations, it is necessary to use the lifting eye:

- Remove lifting eye from case lid.
- Screw locking nut fully onto lifting eye.
- Turn the head upside down and screw lifting eye completely into its seat, then tighten locking nut against the head.

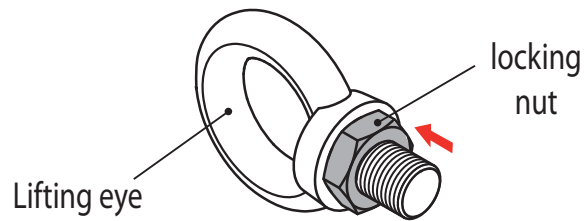

**Before lifting the head, make sure the lifting eye is fully secured otherwise tool damage, personal injury or death may occur.
Never stand under the suspended head.**

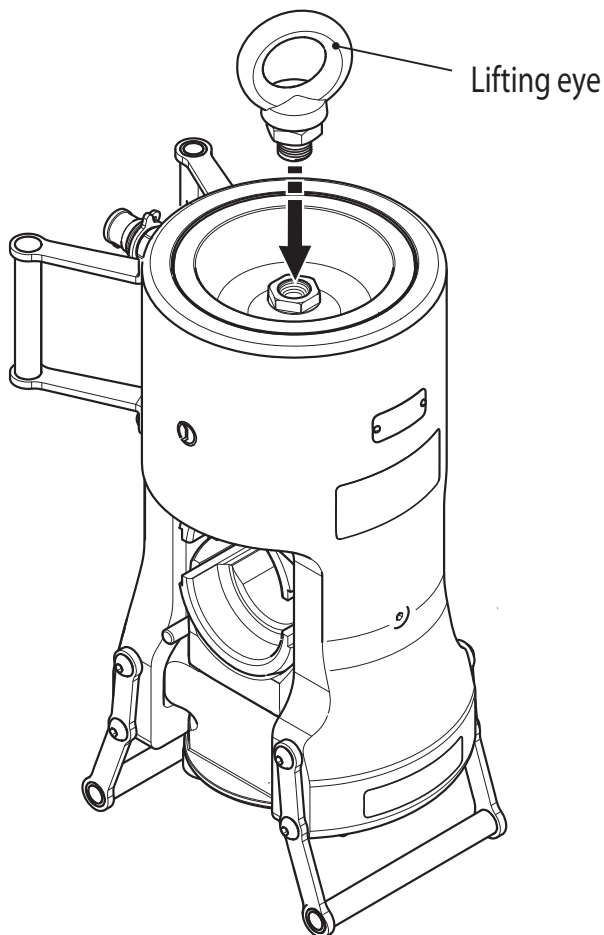

**weight (without dies):
50,7 kg (111.5 lbs)**

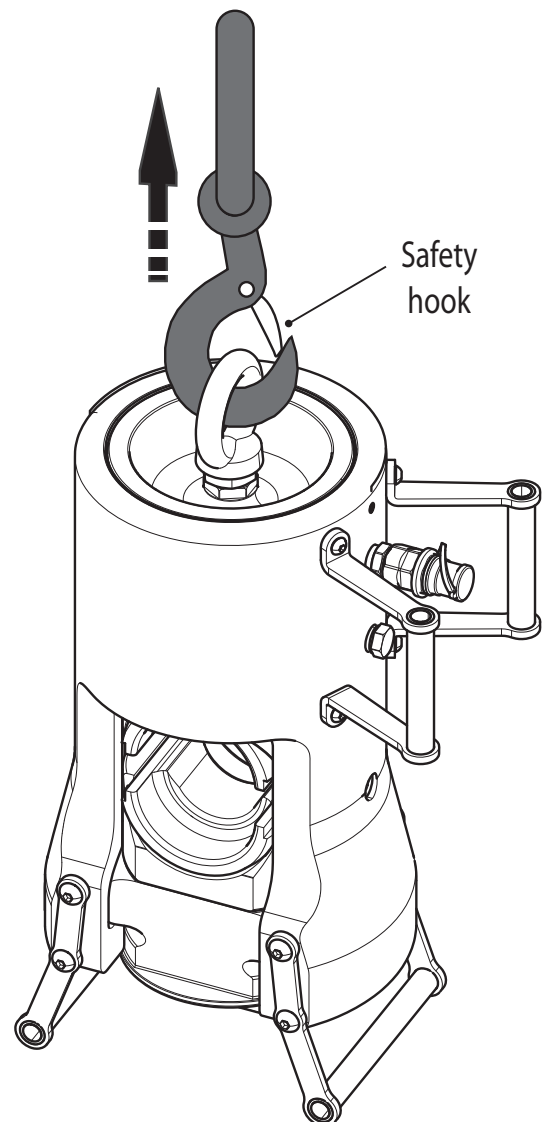

Use a safety hook to lift the head and follow all safety rules required by your employer.

3. MAINTENANCE



Before starting any maintenance operations, always depressurise hydraulic system and disconnect the head from the hose pump.

Compliance with the following points should help to maintain the optimum performance of the tool. The head is robust and requires very little daily maintenance.

The parts must be replaced if signs of wear or damage are evident.

All maintenance or disassembly should take place on a flat, clean work surface covered if necessary so as to have a clean space for the disassembled parts.

Inspect each part during disassembly for wear, scratches, cuts and always replace with new **Cembre** original parts. Worn or damaged parts may malfunction during head operation.

3.1) Accurate cleaning

Dust, sand and dirt are a danger for any hydraulic device.

Avoid putting the head on muddy or dusty ground as dirt particles may score the ram and create oil leaks. Every day, after use, the head must be wiped with a clean cloth, taking care to remove any residue, especially around moving parts.

Occasionally lubricate die stop pins (42 and 43) and latch (9); these parts must also be cleaned and lubricated to prevent sticking.

3.2) Replacement of the supplied automatic coupler

To replace the automatic coupler, proceed as follows:

- Remove the old coupler.
- Carefully clean the thread to remove the old sealant.
- Apply Teflon tape to the thread.
- Fit the new automatic coupler and tighten to 30 Nm (22 lbf ft).

3.3) Storage

The head must be always lifted and transported by two people. When not in use, store and transport the head in the specific steel case to prevent damage. Inside the case lid are specific clips to locate the lifting eye.

VAL1000 steel case:

weight 12 kg (26.5 lbs).

size 334x244x435 mm (13.1x9.6xh17,1in.)

Total weight (presshead + steel case):

63 kg (138 lbs) without dies.

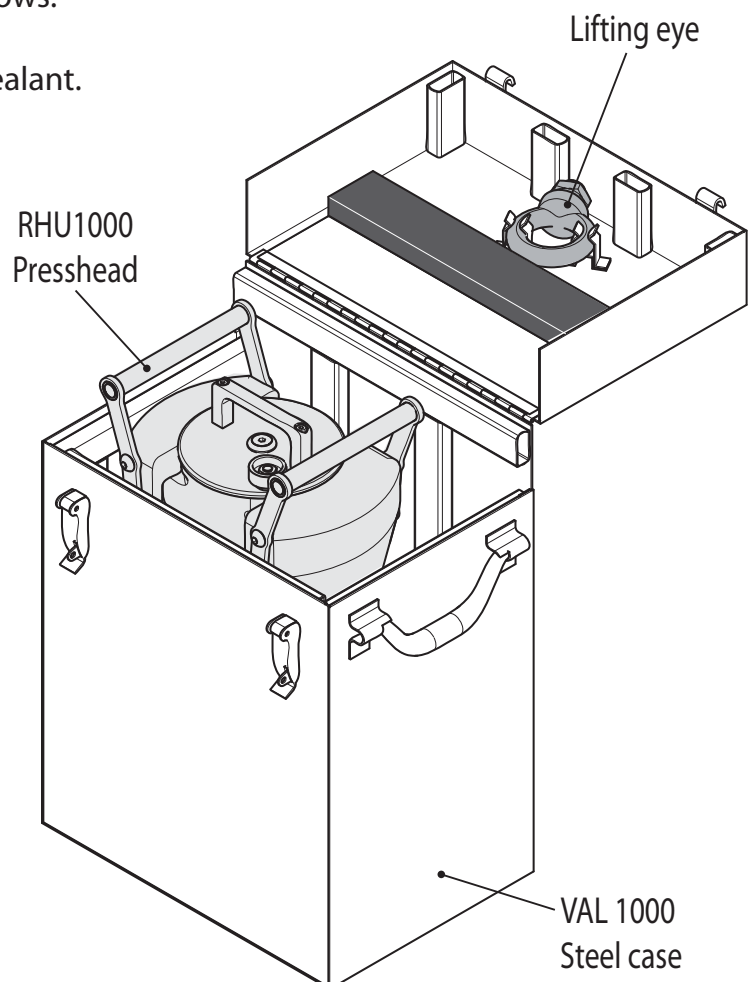

4. CONVERSION INSTRUCTIONS

i Before starting conversion always check that the ram is completely retracted and the pump hose is disconnect from the head.

- FROM SINGLE TO DOUBLE ACTING -

- Remove upper plug vent from the head, insert female coupler Q38-F and nipple 3/8" NPT, using appropriate pipe thread sealant and tighten to 30 Nm (22 lbf ft).
- Connect appropriate high pressure hoses from a suitable power source (10,000 psi) and operate as a double acting hydraulic tool.

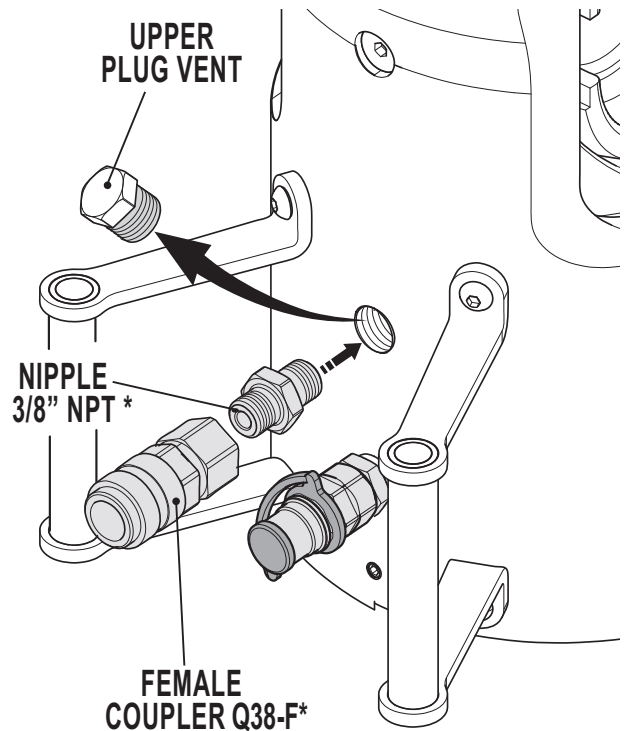

- FROM DOUBLE TO SINGLE ACTING -

- Remove female coupler and nipple from the head.
- Tip the head to pour oil from upper cylinder into a suitable container.
- Insert supplied vent using appropriate pipe thread sealant and tighten to 30 Nm (22 lbf ft). Check that the oil is completely drained, before inserting the plug vent.
- Connect appropriate high pressure hose from a suitable power source and operate as a single acting hydraulic tool.

* optional accessories:
Q38-F code 6060126
NIPPLE code 6525090

UPPER RETURN PORT:
ram returning

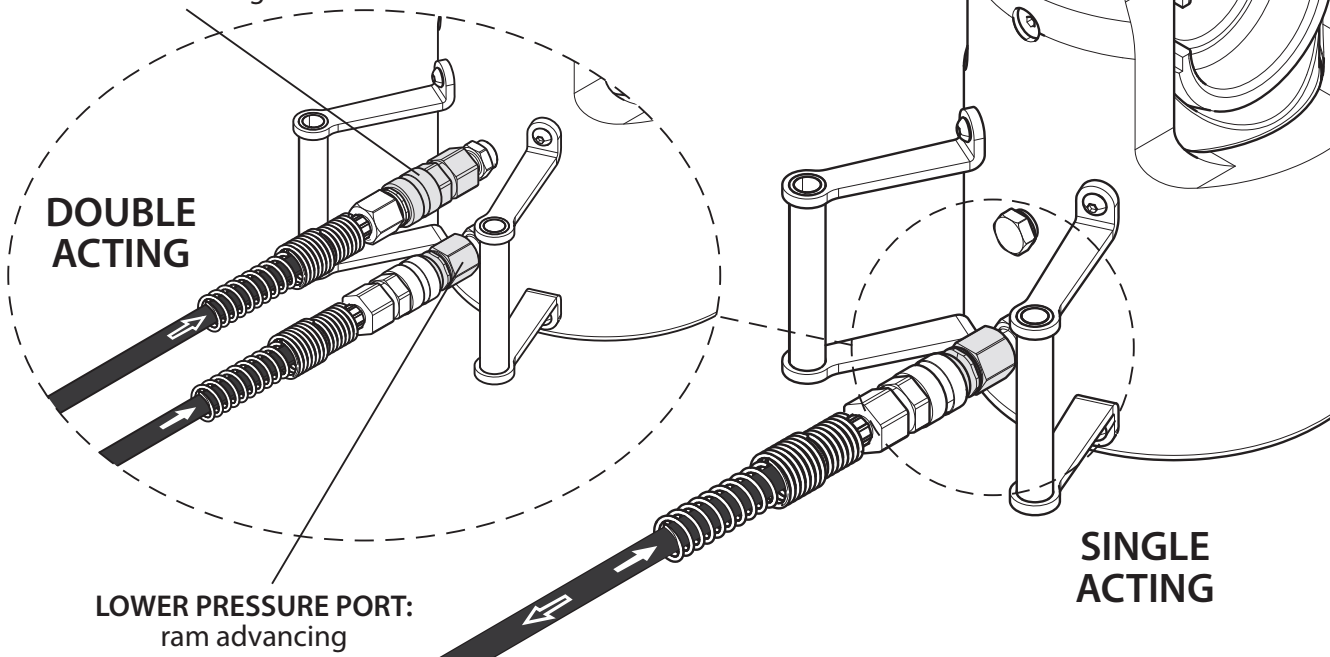

NOTICE: This tool has undergone a magnetic particle inspection (MAGNAFLUX test) and is certified in accordance with ASTM-E1444, MIL-STD-271F, MIL-STD-1907.

SAFETY PRECAUTIONS:

A Non-Destructive Testing (NDT) should be performed by a suitably qualified body after the first two years of service, then annually, and the evidence of the execution marked on the tool, local to its serial number with the date shown as MMY.

Notwithstanding the above, the tool should be regularly inspected and serviced particularly if it is subject to intensive use.

6. SPARE PARTS LIST

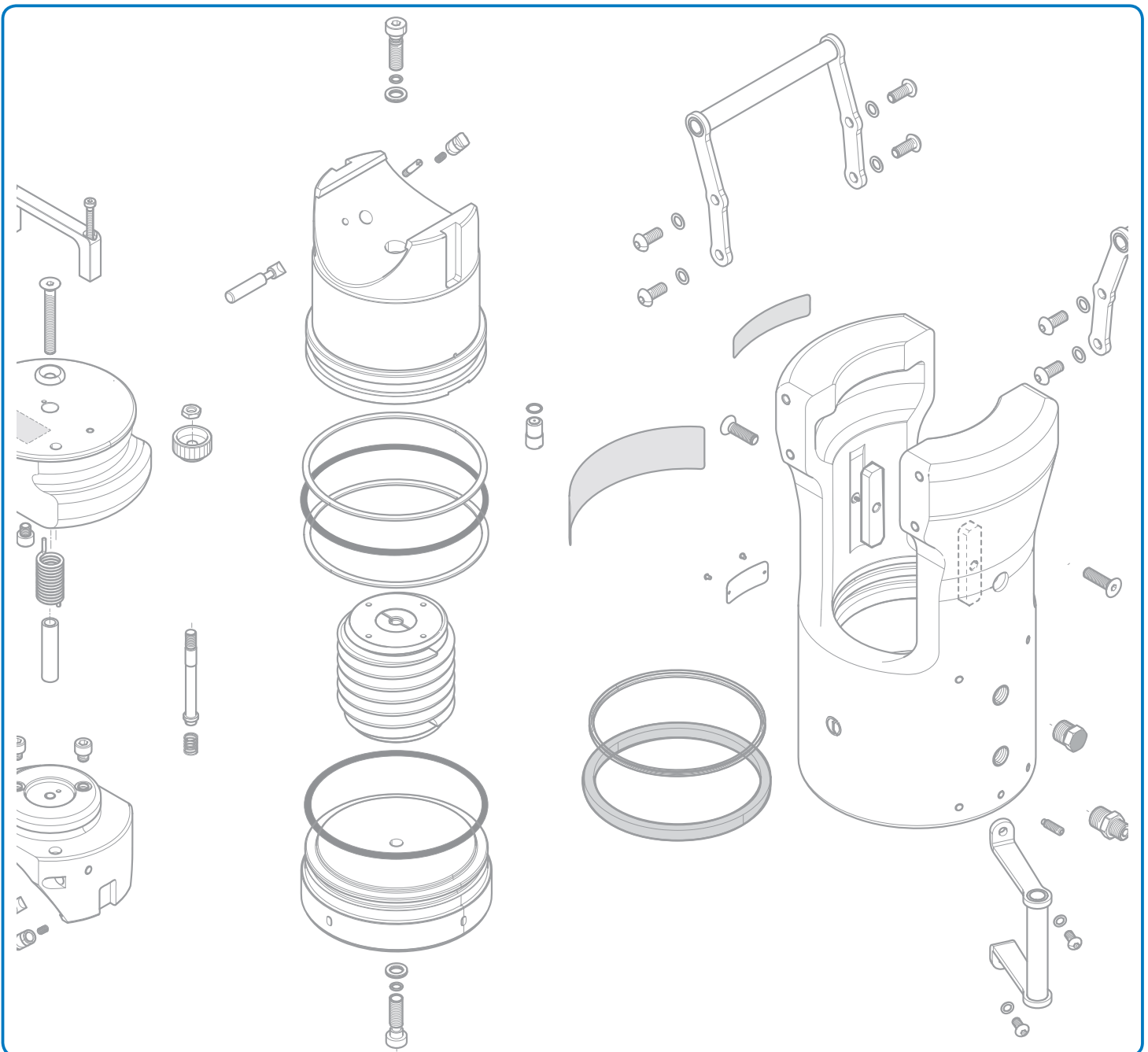

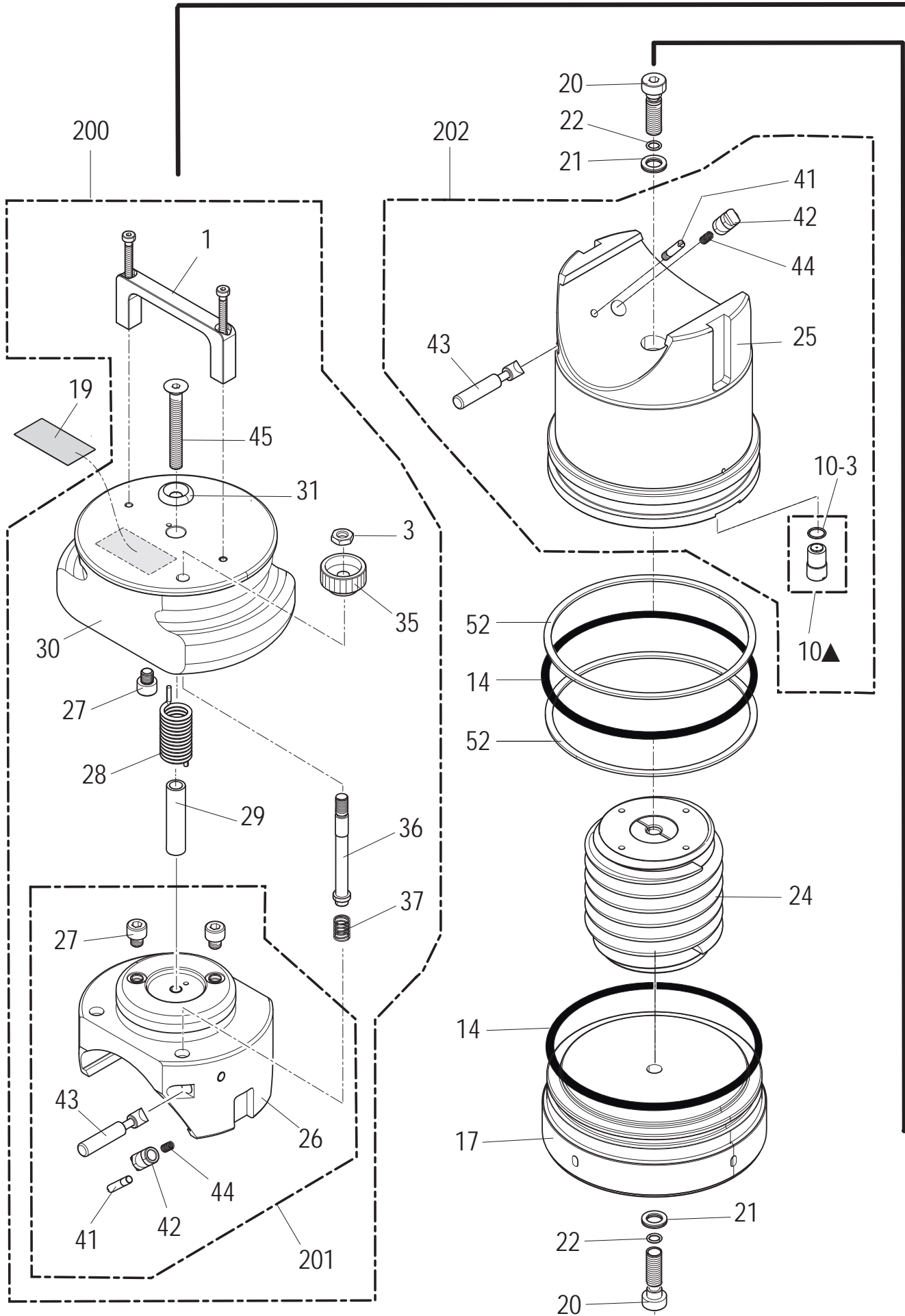

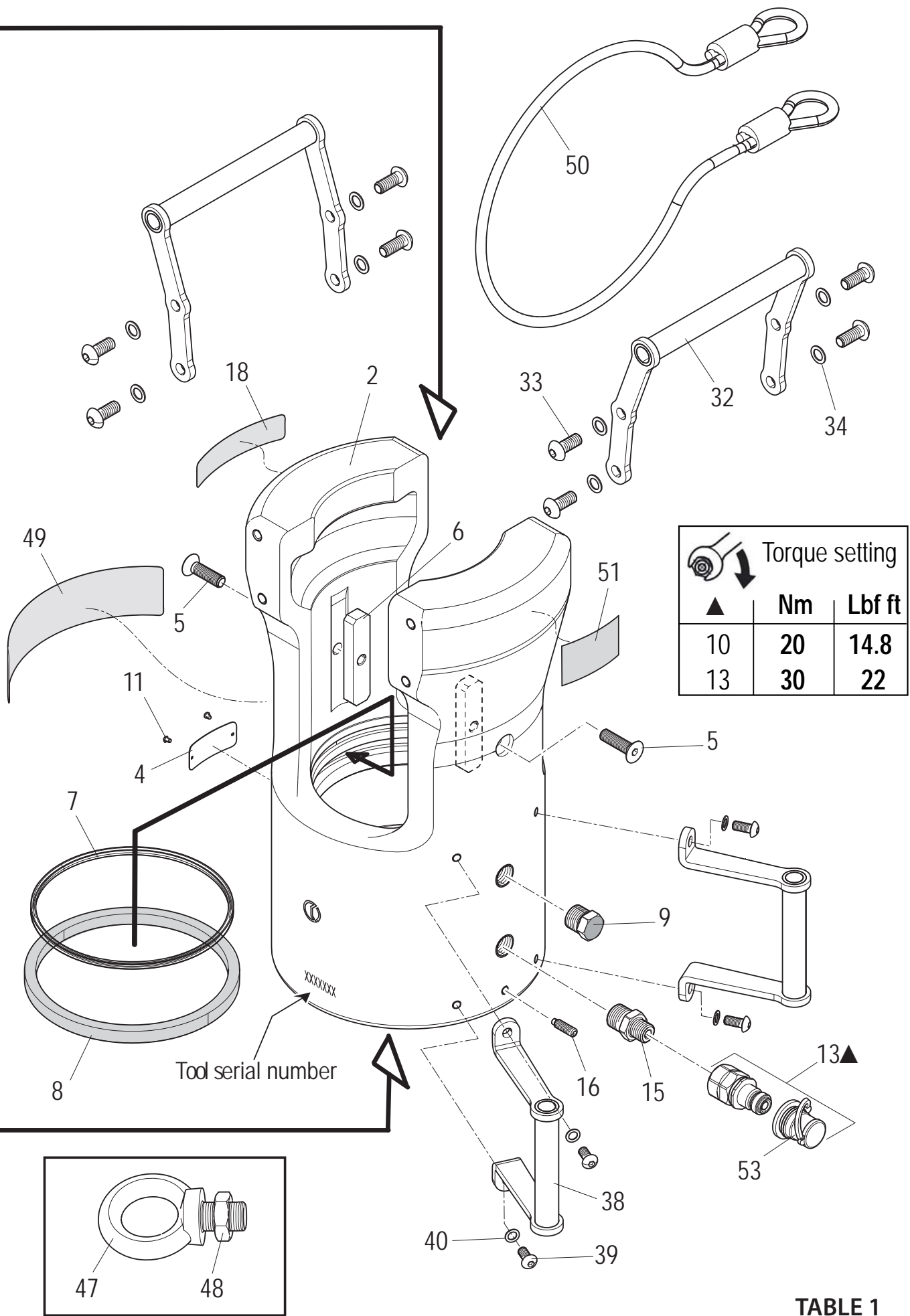

TABLE 1

TABLE 1

The items marked "K" are those **Cembre** recommend replacing if the tool is disassembled.

When ordering spare parts always specify the following:

- code number of item
- name of item
- type of tool
- serial number of tool

The guarantee is void if parts used are not **Cembre** original spares.

Code N°	Item			DESCRIPTION	Qty
-	2			FORK	1
6232683	4			TG.0926 TOOL NAMEPLATE	1
6900426	5			M8x30 SCREW	2
6100043	6			KEY	2
6003936	7			SCRAPER	1 K
6362099	8			SEAL	1 K
6002248	9			PLUG VENT	1
6650118	11			ø2,5x3,5 RIVET	2
6060120	13			Q14-MS QUICK COUPLER + CAP	1
6362100	14			SEAL V1	2 K
6525072	15			3/8"-1/4"MM NPT NIPPLE	1
6340121	16			PLUG VENT	1
6120110	17			BOTTOM PLUG	1
6232006	18			TG.0356 WARNING LABEL	1
6232692	19			TG.0935 WARNING LABEL	1
6900558	20			SCREW	2
6640286	21			Ø6 NL WASHER	2
6362034	22			SEAL V1	2 K
6520443	24			COMPLETE RAM SPRING	1
6490075	32			UPPER HANDLE	2
6900347	33			M8x20 SCREW	8
6640199	34			Ø8 SCHNORR WASHER	8
6490076	38			LOWER HANDLE	2
6900337	39			M6x14 SCREW	4
6640112	40			Ø6 SCHNORR WASHER	4
6370022	47			LIFTING EYE	1
6180990	48			M20 NUT	1
6232691	49			TG.0934 WARNING LABEL	1
6880057	50			D.5 STEEL CABLE	1
6232704	51			TG.0947 WARNING LABEL	1
6040132	52			BACK-UP RING	2 K
6800186	53			PROTECTION CAP	1
6506653	200			TOP DIE HOLDER ASSY	1
6490048	200	1		HANDLE & SCREWS	1
6180301	200	3		M8 NUT	1
6900276	200	27		M8x8 SCREW	1
6520595	200	28		SPRING	1
6080049	200	29		BUSH	1
-	200	30		ADAPTER SUPPORT	1
6640124	200	31		Ø8,3 WASHER	1
6560187	200	35		LATCH	1
6600023	200	36		LOCKING PIN	1
6520561	200	37		SPRING	1
6900427	200	45		M8x65 SCREW	1
6506651	200	201		UPPER ADAPTER ASSY	1
-	200	201	26	UPPER ADAPTER	1
6900276	200	201	27	M8x8 SCREW	2
6760416	200	201	41	POSITIONING PIN	1
6620338	200	201	42	DIE RETAINING PIN	1
6620444	200	201	43	DIE RELEASE PIN	1
6520559	200	201	44	SPRING	1
6620542	202			COMPLETE RAM	1
6895058	202	10		COMPLETE VALVE	1
6362102	202	10	3	SEAL V1	1
-	202	25		RAM	1
6760416	202	41		POSITIONING PIN	1
6620338	202	42		DIE RETAINING PIN	1
6620444	202	43		DIE RELEASE PIN	1
6520559	202	44		SPRING	1

5. RETURN TO Cembre FOR OVERHAULS

In the case of a breakdown, contact our Area Agent who will advise you on the problem and give you the necessary instructions on how to dispatch the tool to our nearest service Centre; if possible, include a copy of the Test Certificate supplied by **Cembre** with the tool or, if no other references are available, indicate the approximate purchase date and the tool serial number.

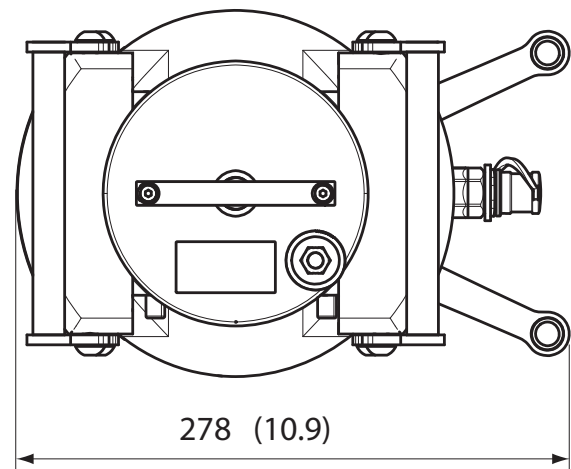
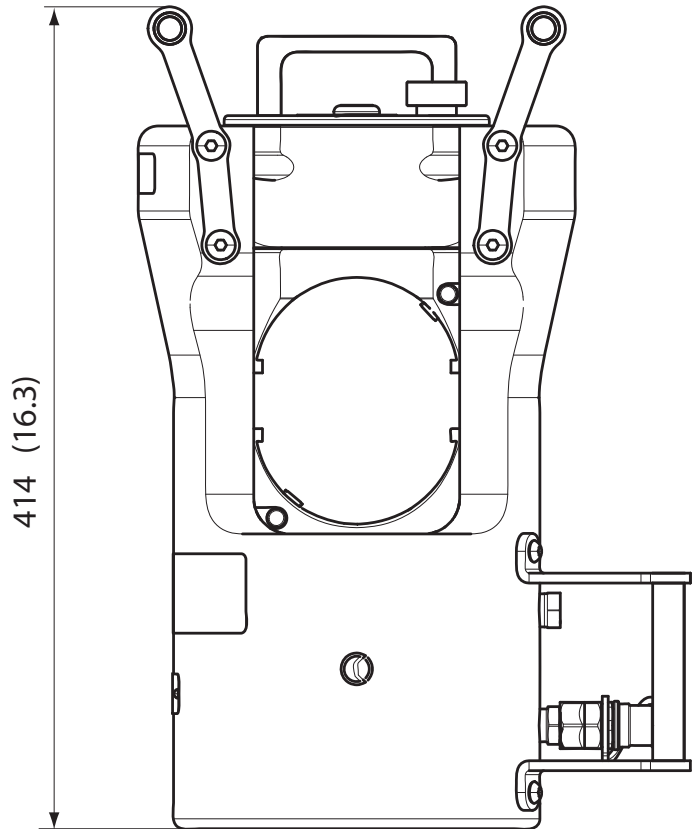
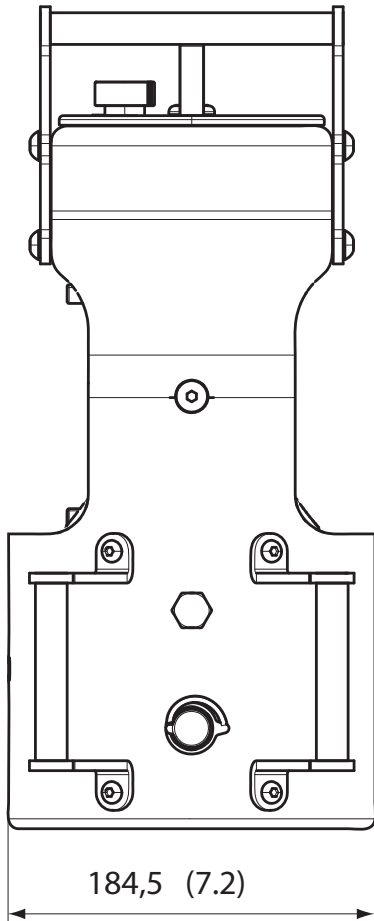

DIMENSIONS mm (inches)

**EU/UE
DECLARATION OF CONFORMITY
DECLARATION DE CONFORMITE
KONFORMITÄTSERKLÄRUNG
DECLARACIÓN DE CONFORMIDAD
DICHIARAZIONE DI CONFORMITÀ**

We Nous Wir Nos Noi **Cembre S.p.A. Via Serenissima, 9 – 25135 Brescia (Italy)**
(supplier's name) (nom du fournisseur) (Name des Anbieters) (nombre del fabricante) (nome del fornitore)

Person authorised to compile the technical file
Personne autorisée à constituer le dossier technique
Person die bevollmächtigt ist die technischen Unterlagen zusammenzustellen
Persona facultada para elaborar el expediente técnico
Persona autorizzata a costituire il file tecnico

..... **Ennio Peroni Via Serenissima, 9 – 25135 Brescia (Italy)**
(name and address) (nom et adresse) (Name und Adresse) (nombre y direccion) (nome e indirizzo)

Declare under our sole responsibility that the product
Déclarons sous notre seule responsabilité que le produit
Erklären in alleiniger Verantwortung daß das Produkt
Declaramos bajo nuestra responsabilidad que el producto
Dichiariamo sotto nostra unica responsabilità che il prodotto

..... **RHU1000**
(type) (type) (Typ) (tipo) (tipo)

.....
(serial number) (no de série) (Seriennummer) (n° de serie) (numero di serie)

To which this declaration relates is in conformity with the following standard(s) or other normative document(s).
Auquel cette déclaration se réfère est conforme à la (aux) norme(s) ou autre(s) document(s) normatif(s)
Auf das sich diese Erklärung bezieht mit der/den folgenden Norm(en) oder normativen Dokument(en) übereinstimmt
Al que se refiere esta declaración, cumple la(s) norma(s) u otro(s) documento(s) normativo(s)
Al quale si riferisce questa dichiarazione è conforme alla(e) norma(e) o altro(i) documento(i) normativo(i)

..... **EN ISO 12100**
(title and/or number) (titre et/ou numéro) (Titel und/oder Nummer) (título y/o número) (titolo e/o numero)

Following the provisions of Directive(s)
Conformément aux dispositions de(s) Directive(s)
Gemäss den Bestimmungen der Richtlinie(n)
De acuerdo con las disposiciones de la(s) Directiva(s)
Conformemente alle disposizioni della(e) direttiva(e)

..... **2006/42/CE**
(title and/or number) (titre et/ou numéro) (Titel und/oder Nummer) (título y/o número) (titolo e/o numero)

 **C e m b r e** S.p.A.
Aldo Bottini Bongrani
Director - Sales and Marketing

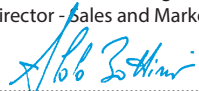

Brescia li 30-11-2012

.....
(Place and date of issue) (Lieu et date) (Ort und Datum der Ausstellung) (Lugar y fecha de emisión) (Luogo e data di emissione)
(name and signature or equivalent marking of authorized person) (nom et signature du signataire autorisé) (Name und Unterschrift oder gleichwertige Kennzeichnung des Befugten) (nombre y firma del signatario autorizado) (nome e firma di persona autorizzata)

16 V202

This manual is the property of **Cembre**: any reproduction is forbidden without written permission.

cod. 6261352

